

ZED



- 2 x 8-digit LC-Display, backlit
- Frequency input:
0.2 - 2000 Hz
- 2 x relay outputs
- Analogue output
- Sensor supply
- Free scaling
- MIN/MAX memory
- Switchboard installation
or field casing



KOBOLD companies worldwide:

ARGENTINA, AUSTRIA, BELGIUM, BULGARIA, CANADA, CHILE, CHINA, COLOMBIA, CZECHIA, DOMINICAN REPUBLIC, EGYPT, FRANCE, GERMANY, GREAT BRITAIN, HUNGARY, INDIA, INDONESIA, ITALY, MALAYSIA, MEXICO, NETHERLANDS, PERU, POLAND, ROMANIA, SINGAPORE, SOUTH KOREA, SPAIN, SWITZERLAND, TAIWAN, THAILAND, TUNISIA, TURKEY, USA, VIETNAM

KOBOLD Messring GmbH
Nordring 22-24
D-65719 Hofheim/Ts.
Head Office:
+49(0)6192 299-0
+49(0)6192 23398
info.de@kobold.com
www.kobold.com



Description

The evaluation unit changes the frequency signal of the pickup into a 3(4)-digit flow reading with adjustable scale (top line of display), and a scalable analogue signal. The dosage is displayed in the bottom line of the display. The unit of measurement can be selected.

Included are two relays with floated output changeover contacts for various functions. The relay (S1) can be used to execute the flow monitoring, total volume monitoring, fine dosage or the pump control.

When the flow is being continuously monitored, it checks if the freely adjustable limits are exceeded or fallen short of. A choice can be made between threshold value and window monitoring. Switching point, hysteresis, window point, and switch-on or switch-off delay can be set as desired. If monitoring of the total volume is selected, a check is made to see if the adjustable quantity limit is exceeded.

The dosage relay (S2) switches on when the dosage process starts, and then switches off again, once the dosage has flowed through. The dosage process can be interrupted by using the Start/Stop switch. By taking a correction quantity into account, it is possible to take any special features or conditions of the system into account. By entering a fine dosage, the bypass valve can be controlled with the relay (S1). A red LED indicates the relay's switching status.

The Analogue output is available as a current output with 0(4)...20 mA or a voltage output with 0...10 V. The parameter names in the menu can be displayed in either German or English. If used where the flow readings change rapidly, the display can be pacified and the analogue reading averaged by switching on some software. If the maximum set flow (exceeded range) is exceeded, it will be shown on the display. The set parameters can be protected against unauthorised alteration using a password function.

Range of functions

Dosage and flow meter with digital display, switch and analogue output:

- Measurement and display of dosage, total and flow quantities
- Free scaling using Teach-In or input of frequency and measured value
- Interval counter (number of dosage process)
- 2 control inputs
- 1 dosage output
- 1 switching output, freely programmable as flow monitor or for monitoring the total quantity
- Analogue output 0(4) ... 20 mA or 0 ... 10 V

Technical Details

Display:	2 x 8-digit alphanumeric LCD module, illuminated
Display rate:	1 s ⁻¹
Flow display:	3- or 4-digit (XX.X, X.XX or XXXX)
Flow units:	ml/s, ml/m, l/s, l/m, l/h, m ³ /m, m ³ /h, GPM, GPH, user unit per h/min/s selectable
Quantity meter:	8-digit
Dosage:	5-digit
Quantity units:	ml, l, m ³ , gal, mgal, user unit selectable
Measurement input:	0.2 ... 2000 Hz (5 ... 24 V _{DC}), TTL, PNP, NPN, Namur
Parameter input:	menu controlled, German or English
Parameter protection:	4-digit password
Control elements:	4 keys
Custom. comparison:	by entering the frequency and measured value or in the Teach-In procedure (level calibration)
Control inputs:	start, stop, reset function
Relay outputs:	2 x changer max. 250 V _{AC/DC} max. 5 A / 1000 VA
Voltage supply:	24 V _{DC} ±20%, approx. 80 mA or 90 ... 250 V _{AC} / max. 3 VA
Analogue output:	0(4) ... 20 mA Load: max. 500 Ω, (at AC-supply: 300) or 0 ... 10 V (Load: >100 k)
Sensor supply:	15 V (at 24 V _{DC}) / max. 50 mA 12 V (AC-supply) / max. 50 mA
Ambient temperature:	-20 ... +70 °C
Dimensions:	96 x 96 x 109 mm (L x W x D) incl. screw clamp (control panel installat.) 117 x 117 x 127 mm (L x W x D) (field casing)
Aperture size:	92 ^{+0,8} x 92 ^{+0,8} mm (control panel installation)

Technical Details (continued)

Casing material: fibreglass reinforced Noryl (control panel installation)
 powder coated aluminium/PA 66 (field casing)

Protection: IP 40 on front
 clamp IP 00 (control panel installation)
 IP 65 (field casing)

Mounting: mounting clip Form B (DIN 43 835) (control panel installation)
 wall and pipe mounting (field casing)

Connection: plug-in terminal strip (control panel installation)
 cable connection (field casing)

Weight: approx. 360 g (control panel installation)
 approx. 1240 g (field casing)

Electrical connection

- 14 — Control 1
- 13 — Control 1 - GND
- 12 — Control 2
- 11 — Control 2 - GND
- 10 — Sensor supply
- 9 — Analog GND
- 8 — Analog 10 V
- 7 — Analog 20 mA
- 6
- 5
- 4 — GND
- 3 — f-Input Namur
- 2 — f-Input NPN
- 1 — f-Input PNP

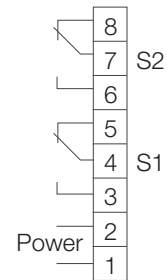

Order details (Example: ZED-DF10 KS 4R P)

Supply	Model	Electrical connection	Analogue output	Housing
90 ... 250 V _{AC}	ZED-DF10	KS = terminal strip (control panel installation)	4R = 0(4) ... 20 mA	P = control panel installation 96 x 96 mm F = field casing 116 x 116 mm S = field casing with wall mount, infinitely variable pivotable R = field casing with 2"-pipe mounting
24 V _{DC}	ZED-DF13	MS = cable connection M18 (field casing)	1R = 0 ... 10 V	

Dimensions

Control panel installation (Housing P)

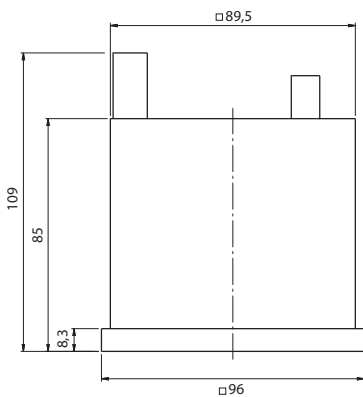

Field casing

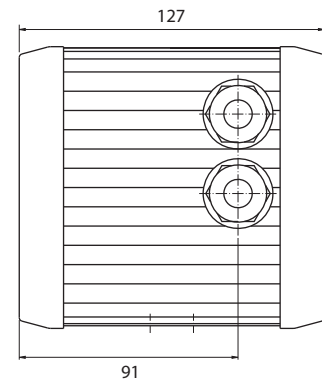
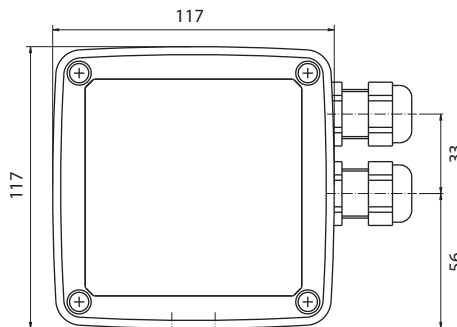



Description

The evaluation unit changes the frequency signal of the pickup into a 3(4)-digit flow reading with selectable measurement unit (top display line), and into a scalable analogue signal. The flow quantity is added up in a part quantity meter and a total quantity meter and then displayed in the bottom line of the screen. The quantity meter's units of measurement are selectable.

The two relays with floating output changeover contacts continuously monitor if the freely adjustable limits are exceeded or fallen short of. Here, it is possible to choose between threshold value and window monitoring.

Switching point, hysteresis, a window point, and switch on or off delay can be set separately for each relay. The switching points can also be set directly by using the control keys without having to change over into the menu. Alternatively, it is also possible to monitor the quantity meter to see if it is exceeded. A red LED indicates with the switching status.

The analogue output is optionally available as current output with 0(4)...20 mA or as voltage output with 0...10 V. The Parameter names can be shown in the menu in German or English. If used where the flow readings change rapidly, the display can be pacified and the analogue reading averaged by switching on some software.

A MIN/MAX reading memory determines the extreme readings of the flow. The display of the readings and the resetting are achieved by using the keys without having to change into the menu. Resetting by using the keys can also be blocked. If the maximum set flow (exceeded range) is exceeded, it will be shown on the display.

The set parameters can be protected against unauthorised alteration by using a password function.

Range of functions

Quantity meter and flow meter with digital display, switch and analogue output:

- Measurement and display total, part and flow quantities
- Free scaling using Teach-In or input of frequency and measured value
- Control input for part quantity reset
- 2 switching outputs, freely programmable as flow monitor or for monitoring the part and total quantity
- Analogue output 0(4) ... 20 mA or 0 ... 10 V
- MIN/MAX memory

Technical Details

Display:	2 x 8-digit alphanumeric LCD module, illuminated
Display rate:	1 s ⁻¹
Flow display:	3- or 4-digit (XX.X, X.XX or XXXX)
Flow units:	ml/s, ml/m, l/s, l/m, l/h, m ³ /m, m ³ /h, GPM, GPH, user unit per h/min/s selectable
Quantity meter:	8-digit
Quantity units:	ml, l, m ³ , gal, mgal, user unit selectable
Measurement input:	0.2 ... 2000 Hz (5 ... 24 V _{DC}), TTL, PNP, NPN, Namur
Parameter input:	menu controlled, German or English
Parameter protection:	4-digit password
Control elements:	4 keys
Custom. comparison:	by entering the frequency and measured value or in the Teach-In procedure (level calibration)
Control inputs:	reset function
Relay outputs:	2 x changer max. 250 V _{AC/DC} max. 5 A/1000 VA
Voltage supply:	24 V _{DC} ±20%, approx. 80 mA or 90 ... 250 V _{AC} /max. 3 VA
Analogue output:	0(4) ... 20 mA Load: max. 500 Ω, (at AC-supply: 300) or 0 ... 10 V (Load: >100 k)
Sensor supply	15 V (at 24 V _{DC}) / max. 50 mA 12 V (AC-supply)/ max. 50 mA
Ambient temperature:	-20 ... +70 °C
Dimensions:	96 x 96 x 109 mm (L x W x D) incl. screw clamp (control panel installation) 117 x 117 x 127 mm (L x W x D) (field casing)
Aperture size:	92 ^{+0,8} x 92 ^{+0,8} mm (control panel installation)



Technical Details (continued)

Casing material: fibreglass reinforced Noryl (control panel installation)
 powder coated aluminium/PA 66 (field casing)

Protection: IP 40 on front
 clamp IP 00 (control panel installation)
 IP 65 (field casing)

Mounting: mounting clip Form B (DIN 43 835) (control panel installation)
 wall and pipe mounting (field casing)

Connection: plug-in terminal strip (control panel installation)
 cable connection (field casing)

Weight: approx. 360 g (control panel installation)
 approx. 1240 g (field casing)

Electrical connection

- 14 — Control 1
- 13 — Control 1 - GND
- 12 — Control 2
- 11 — Control 2 - GND
- 10 — Sensor supply
- 9 — Analog GND
- 8 — Analog 10 V
- 7 — Analog 20 mA
- 6
- 5
- 4 — GND
- 3 — f-Input Namur
- 2 — f-Input NPN
- 1 — f-Input PNP

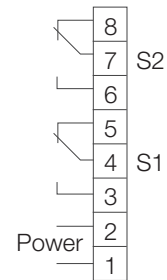

Order details (Example: ZED-ZF10 KS 4R P)

Supply	Model	Electrical connection	Analogue output	Housing
90 ... 250 V _{AC}	ZED-ZF10	KS = terminal strip (control panel installation)	4R = 0(4) ... 20 mA	P = control panel installation 96 x 96 mm F = field casing 116 x 116 mm S = field casing with wall mount, infinitely variable pivotable R = field casing mit 2"-pipe mounting
24 V _{DC}	ZED-ZF13	MS = cable connection M18 (field casing)	1R = 0 ... 10 V	

Dimensions

Control panel installation (Housing P)

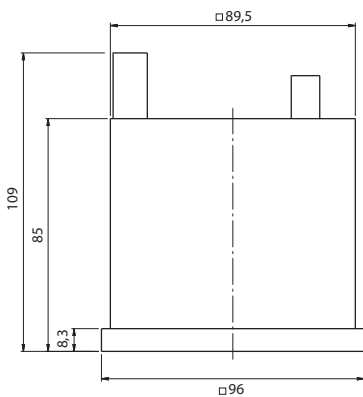

Field casing

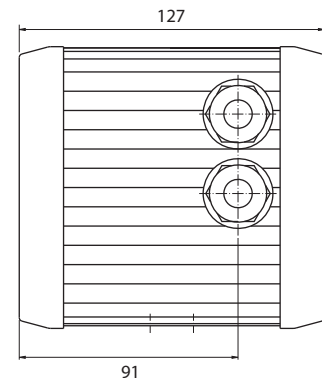
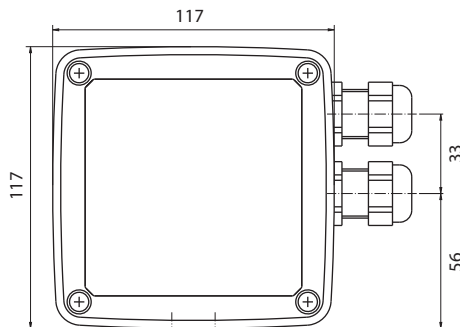



Description

The evaluation unit changes the frequency signal of the pickup into a 3(4)-digit flow reading with selectable measuring unit and into a scalable analogue signal. The two threshold value relays with floating output changeover contacts continuously monitor the flow to check if the freely settable limits are exceeded or fallen short of. Here, it is possible to select either threshold value or window monitoring. The switching point, the hysteresis, a window point and the switch on or off delay can be set separately for each relay. The switching points can also be set directly using the control keys without having to switch over into the menu. A red LED indicates the switching statuses.

The bottom line of the display shows a bar graph of the flow readings. The analogue output is available as current output with 0(4)...20 mA or as voltage output with 0...10 V. The parameter names in the menu can be shown in German or English. If used where the flow readings change rapidly, the display can be pacified and the analogue reading averaged by switching on some software.

A MIN/MAX reading memory determines the extreme values of the flow. The display of the readings and the resetting are achieved by using the keys, without having to change into the menu. Resetting by using the keys can also be blocked.

If the maximum set flow (exceeded range) is exceeded, it will be shown on the display. The set parameters can be protected against unauthorised alteration by using a password function.

Range of functions

Flow monitor with digital display, switching and analogue output:

- Metering and display of the flow quantity
- Free scaling using Teach-In or entering the frequency and measured value
- 2 switching outputs, freely programmable
- Analogue output 0(4) ... 20 mA or 0 ... 10 V
- MIN/MAX memory

Technical Details

Display:	2 x 8-digit alphanumeric LCD module, illuminated 3- or 4-digit (XX.X, X.XX or XXXX) bar graph in the second line
Display rate:	1 s ⁻¹
Flow units:	ml/s, ml/m, l/s, l/m, l/h, m ³ /m, m ³ /h, GPM, GPH, user unit per h/min/s selectable
Measurement input:	0.2 ... 2000 Hz (5 ... 24 V _{DC}), TTL, PNP, NPN, Namur
Parameter input:	menu controlled, German or English
Parameter protection:	4-digit password
Control elements:	3 keys
Custom. comparison:	by entering the frequency and measured value or in the Teach-In procedure (level calibration)
Relay outputs:	2 x changer max. 250 V _{AC/DC} / 2 A
Voltage supply:	24 V _{DC} ±20%, approx. 80 mA or 90 ... 250 V _{AC} / max. 3 VA
Analogue output:	0(4) ... 20 mA Load: max. 500 Ω, (at AC-supply: 300) or 0 ... 10 V (Load: >100 k)
Sensor supply:	15 V (at 24 V _{DC}) / max. 50 mA 12 V (AC-supply) / max. 50 mA
Ambient temperature:	-20 ... +70 °C
Dimensions:	96 x 96 x 109 mm (L x W x D) incl. screw clamp (control panel installation) 117 x 117 x 127 mm (L x W x D) (field casing)
Aperture size:	92 ^{+0,8} x 92 ^{+0,8} mm (control panel installation)
Casing material:	fibreglass reinforced Noryl (control panel installation) powder coated aluminium/PA 66 (field casing)
Protection:	IP 40 on front clamp IP 00 (control panel installation) IP 65 (field casing)
Mounting:	mounting clip Form B (DIN 43 835) (control panel installation) wall and pipe mounting (field casing)
Connection:	plug-in terminal strip (control panel installation) cable connection (field casing)
Weight:	approx. 360 g (control panel installation) approx. 1240 g (field casing)

Order details (Example: ZED-KF10 KS 4R P)

Supply	Model	Electrical connection	Analogue output	Housing
90 ... 250 V _{AC}	ZED-KF10	KS = terminal strip (control panel installation)	4R = 0(4) ... 20 mA	P = control panel installation 96 x 96 mm
24 V _{DC}	ZED-KF13	MS = cable connection M18 (field casing)	1R = 0 ... 10 V	F = field casing 116 x 116 mm S = field casing with wall mount, infinitely variable pivotable R = field casing mit 2"-pipe mounting

Dimensions

Control panel installation (Housing P)

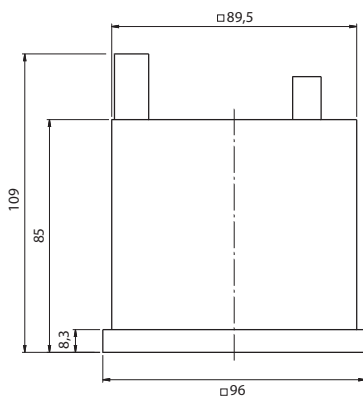

Field casing

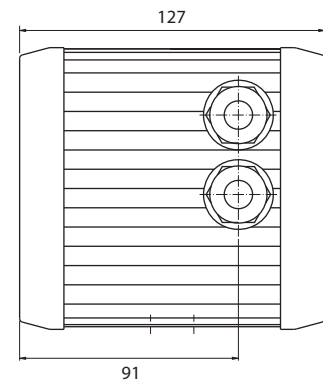
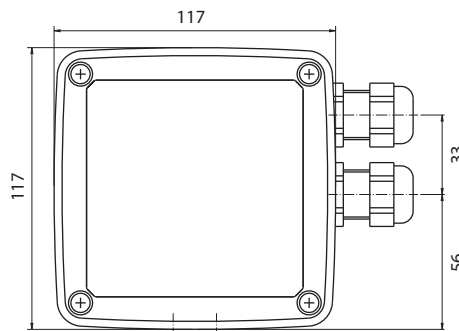

Electrical connection

