



# SERIES AP 1400T

## TIED DIAPHRAGM REGULATOR

Intermediate to high flow applications

- Single stage
- Stainless steel 316L VAR secondary remelt construction
- Absolute sub-atmospheric option, flow rate to 6 slpm
- Cylinder or point of use specialty and bulk gases
- Flow rates to 600 slpm (21 scfm)
- Vacuum to 2,300 psig (159 bar) inlet  
HR option to 3,000 psig (207 bar)
- Designed and manufactured exclusively for UHP semiconductor applications
- Installation and operating instructions available at [www.aptech-online.com](http://www.aptech-online.com) in the Tech Briefs section

### Operating Parameters

Source pressure	AP 1400T	vacuum to 2,300 psig (159 bar)
	AP 1400TA	vacuum to 300 psig (21 bar)
	AP 1400T HR	vacuum to 3,000 psig (207 bar)
Delivery pressure	AP 1402TA	100 mm Hg absolute to 30 psig (2 bar) <small>(not available for HR)</small>
	AP 1402T	1 to 30 psig (0.07 to 2 bar) <small>(not available for HR)</small>
	AP 1406T	1 to 60 psig (0.07 to 4 bar) <small>(not available for HR)</small>
	AP 1410T	2 to 100 psig (0.14 to 7 bar)
	AP 1415T*	5 to 150 psig (.34 to 10 bar)
Proof pressure		4,000 psig (276 bar); HR option 4,500 psig (310 bar)
Burst pressure		8,000 psig (552 bar); HR option 9,000 psig (620 bar)

### Other Parameters

Inlet/outlet connectors	1/4, 3/8 or 1/2 inch face seal or tube weld
Bonnet port	1/8 inch NPT
Flow coefficient (Cv)	0.45
Internal volume	1.06 in <sup>3</sup> (17.4 cm <sup>3</sup> )
Operating temperature	-40° to +160°F (-40° to +71°C)
Surface finish	15 µin Ra max / 10 µin. Ra avg. (0.4/0.25 µm) standard; 10 µin (0.25 µm); 7 µin (0.18 µm); and 5 µin (0.13 µm) Ra max optional
Inboard leakage	2 x 10 <sup>-10</sup> sccs
Outboard leakage	2 x 10 <sup>-9</sup> sccs He
Leakage across seat	4 x 10 <sup>-8</sup> sccs He
Installation	surface or panel (optional)
Supply pressure effect	1.6 psig per 100 psig source pressure change

### Materials

	Series AP 1400T S Corrosive	Series AP 1400T SH Corrosive
Type of Service		
Wetted Parts		
Body	SS 316L secondary remelt	SS 316L secondary remelt
Poppet and diaphragm	Ni-Cr-Mo alloy / UNS N06022	Ni-Cr-Mo alloy / UNS N06022
Nozzle	SS 316L	Ni-Cr-Mo alloy / UNS N06022
Finish	electropolished and passivated	electropolished and passivated
Seat	PCTFE (Polyimide optional)	PCTFE

All specifications subject to change without notice.

\*AP 1415T will not achieve full outlet pressure rating at all inlet pressures.

# ULTRACLEAN BY DESIGN

## DIMENSIONAL INFORMATION

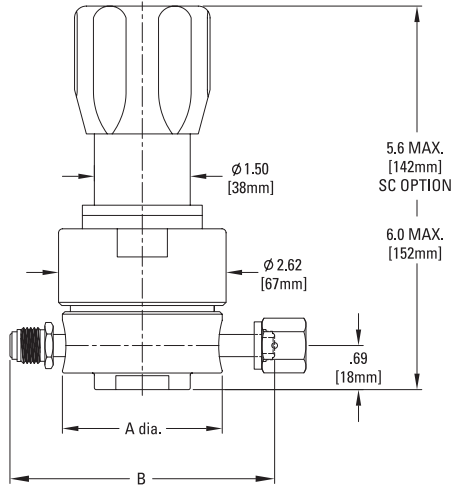

Face Seal	A	B
1/4" Male	2.00" (51 mm)	4.00" ±.02 (102 mm)
1/4" Female	2.00" (51 mm)	3.70" ±.02 (94 mm)
3/8"	2.50" (64 mm)	5.22" ±.03 (133 mm)
1/2"	2.50" (64 mm)	5.22" ±.03 (133 mm)

All dimensions in inches (mm). Metric dimensions are for reference only.

## PORTING CONFIGURATIONS

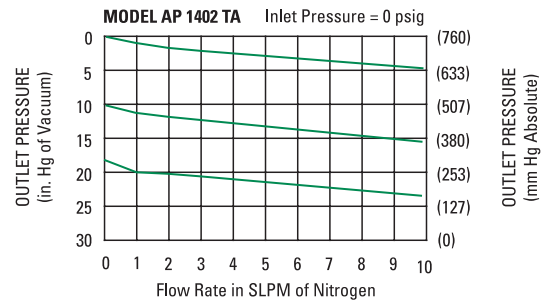
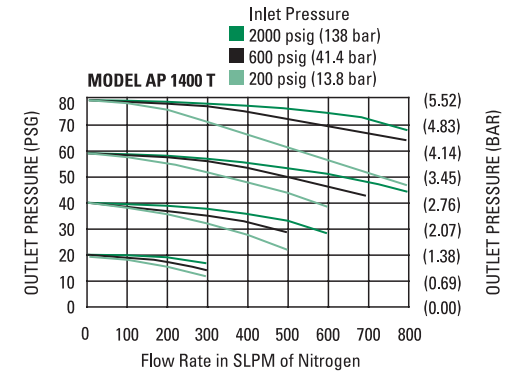
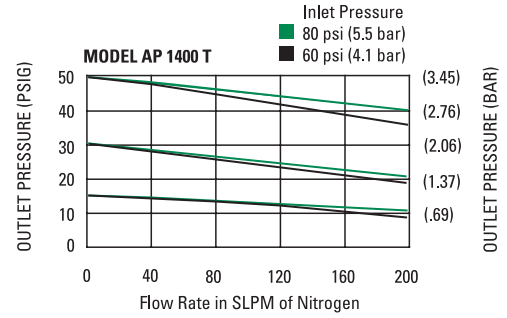
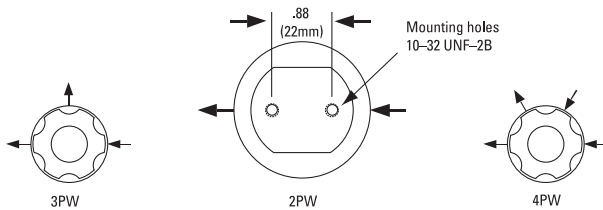

**CAUTION: Product selection is the sole responsibility of the user, regardless of any recommendations or suggestions made by the factory. The user shall make selections based upon their own analysis and testing with regard to function, material compatibility and product ratings. Proper installation, operation and maintenance are also required to assure safe, trouble free performance.**

## ORDERING INFORMATION

Sample Order Number	AP 1402T SMA 3PW FV4 FV4 V3	
<b>AP 1402T</b>   Series	AP 1402T = 1-30 psig (.07 to 2 bar)	<b>FV4 FV4</b>   Connections Inlet / Outlet  FV4 = 1/4 inch face seal female MV4 = 1/4 inch face seal male FV6 = 3/8 inch face seal female MV6 = 3/8 inch face seal male FV8 = 1/2 inch face seal female MV8 = 1/2 inch face seal male Tube weld stub available
	AP 1406T = 1-60 psig (.07 to 4 bar)	
	AP 1410T = 2-100 psig (.14 to 7 bar)	
<b>S</b>   Material	S = Stainless steel (SHP)* SH = SS/Ni-Cr-Mo alloy internals	<b>V3</b>   Gauges Source / Delivery  Standard gauge ports are 1/4 inch face seal male. (1/4 inch face seal female are available).  <b>Options</b> On panel mount option, bonnet port is not threaded. Panel hole 1.56" diameter. *SC option not available with 1402T option.
<b>M</b>   Surface Finish Options	M = 10 µin. Ra max V = 7 µin. Ra max X = 5 µin. Ra max	
<b>A</b>   Range Options	A = 100 mm Hg absolute to 30 psig (2 bar) (AP 1402T option only)	
<b>3PW</b>   Ports	2PW = 2 ports butt weld face seal 3PW = 3 ports butt weld face seal 4PW = 4 ports butt weld face seal	
		0 = No gauge V3 = 30-0-30 psig/bar L = 30-0-60 psig/bar 1 = 30-0-100 psig/bar 2 = 0-200 psig/bar 4 = 0-400 psig/bar 10 = 0-1000 psig/bar 40 = 0-4000 psig/bar  P = Panel installation ring VS = Polyimide seat HR = High inlet pressure SC = Short, single piece bonnet*

**AP Tech has product options and variations which are not documented in data sheets. If you have a model number that is not defined by the ordering information, please consult the factory or your local representative.**

\*S equivalent to SHP – stainless steel with Ni-Cr-Mo alloy poppet and diaphragm