



SERIES AZ 12PA

SINGLE STAGE REGULATOR

PNEUMATIC ACTUATION

Flow Rates to 1,000 SLPM (52 scfm)

- 100 psig outlet achieved with 80 psig control pressure or less
- Actuation control pressure isolated from process gas
- SS 316L construction
- 10 µin. surface finish (25 µin. optional)
- Flow rates
 - standard to 800 slpm (28 scfm)
 - HF option to 1,000 slpm (35 scfm)
- Point of use or cylinder specialty and bulk gases
- Vacuum to 1,700 psig (117 bar) inlet
HR Option – vacuum to 3,000 psig (207 bar)
- ‘Fail safe’ normally closed (NC) actuation
- Installation and operating instructions available at www.aptech-online.com in the Tech Briefs section

Operating Parameters

Source pressure	AZ 12PA	vacuum to 1,700 psig (117 bar)
	AZ 12PA HR	vacuum to 3,000 psig (207 bar)**
Delivery pressure	AZ 12PA	7 to 150 psig (0.5 to 10 bar)
Proof pressure		2,550 psig (176 bar)
	AZ 12PA HR	4,500 psig (310 bar)
Burst pressure		8,000 psig (552 bar)
	AZ 12PA HR	9,000 psig (620 bar)
Control pressure		150 psig (10 bar) maximum

Other Parameters

Inlet/outlet connectors	1/4, 3/8, 1/2 inch face seal or tube weld
Flow coefficient (Cv)	0.9 (HF = 1.1)**
Control pressure port	1/8 inch NPT
Bonnet vent port	1/8 inch NPT
Internal volume	1.20 in ³ (19.6 cm ³)
Operating temperature	-40° to +160°F (-40° to +71°C)
Surface finish	10 µin. (0.25 µm) Ra avg. 25 µin. (0.62 µm) optional
Inboard leakage	2 x 10 ⁻¹⁰ sccs
Outboard leakage	2 x 10 ⁻⁹ sccs He
Leakage across seat	4 x 10 ⁻⁸ sccs He
Installation	surface
Supply pressure effect	3.5 psig per 100 psig source pressure change
	HF 4.2 psig per 100 psig source pressure change

Materials

	Series AZ 12PA S	Series AZ 12PA SHP
Wetted Parts		
Body, nozzle	stainless steel 316L*	stainless steel 316L*
Poppet	stainless steel 316L	Ni-Cr-Mo alloy / UNS N06022
Diaphragm	Ni-Cr-Mo alloy / UNS N06022	Ni-Cr-Mo alloy / UNS N06022
Finish	electropolished and passivated	electropolished and passivated
Seat	PCTFE (Polyimide optional)	PCTFE

All specifications subject to change without notice.

*Please refer to product note PN 414 regarding single melt 316L SS material.

**HR and HF option will not achieve rated outlet pressures at all inlet pressures.

SERVICE AND SUPPORT BEYOND COMPARE

DIMENSIONAL INFORMATION

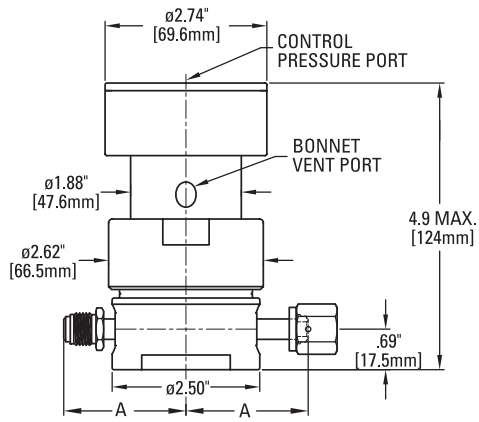

Face Seal	A	
	in	mm
1/4"	2.15 ±.01	55
3/8", 1/2"	2.61 ±.02	66

All dimensions in inches (mm).

PORTING CONFIGURATIONS

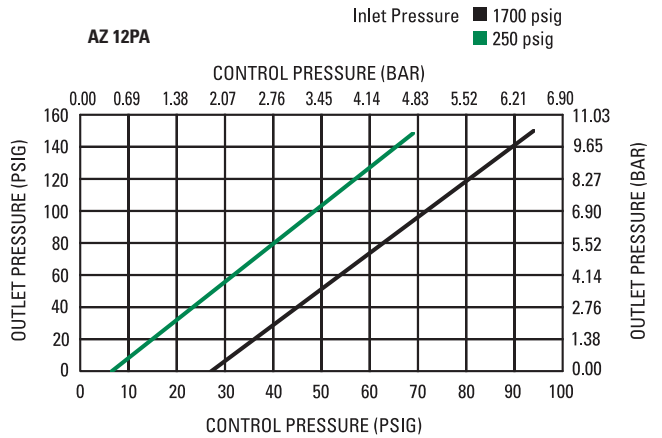
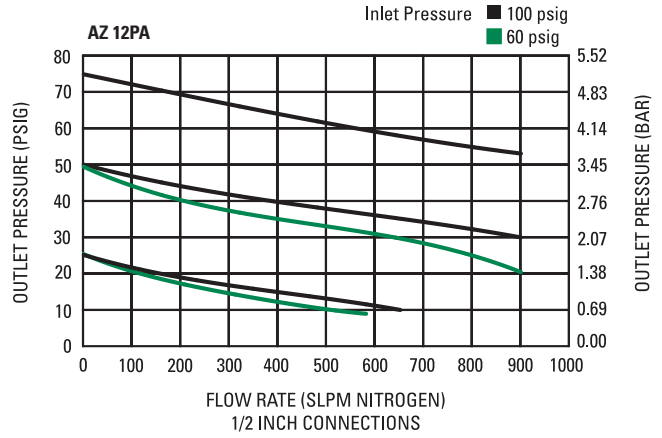
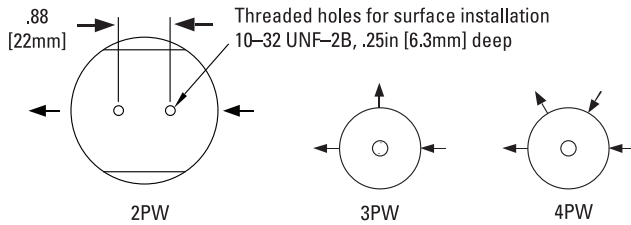

CAUTION: Product selection is the sole responsibility of the user, regardless of any recommendations or suggestions made by the factory. The user shall make selections based upon their own analysis and testing with regard to function, material compatibility and product ratings. Proper installation, operation and maintenance are also required to assure safe, trouble free performance.

ORDERING INFORMATION

Sample Order Number	AZ 12PASQ 3PW FV8 FV8 V3 HR	
AZ 12PA Series	AZ 12PA = 7-150 psig (.5 to 10 bar)	
S Material	S = Stainless steel (SS) SHP = SS/Ni-Cr-Mo alloy poppet and diaphragm	
Q Surface Finish Option	Q = 25 µin. Ra avg.	
3PW Ports	2PW = 2 ports butt weld 3PW = 3 ports butt weld 4PW = 4 ports butt weld	
FV8 FV8 Connections Inlet / Outlet	FV4 = 1/4 inch face seal female MV4 = 1/4 inch face seal male FV6 = 3/8 inch face seal female MV6 = 3/8 inch face seal male FV8 = 1/2 inch face seal female MV8 = 1/2 inch face seal male Tube weld stub available	
V3 Gauges* Source / Delivery	0 = No gauge V3 = 30-0-30 psig/bar L = 30-0-60 psig/bar 1 = 30-0-100 psig/bar 2 = 0-200 psig/bar 4 = 0-400 psig/bar 10 = 0-1000 psig/bar 40 = 0-4000 psig/bar * Standard gauge ports are 1/4 inch face seal male (1/4 inch face seal female are available).	
HR Options	HR = High Inlet Pressure** HF = High Flow** VS = Polyimide seat **HR and HF options are only available separately. These options may not be combined. Full rated outlet pressure may not be achieved at all inlet pressures.	