

Steam Traps

Float-controlled Steam Traps KA 2X

Universal Valve for Larger Flow Rates



Technical Data

Connection DN	25 x 3/4A
Connection G	1 x 3/4A
Nominal Pressure PN	16
Operating Pressure	0 - 13
Flow Rate	1200 l/h
Temperature	190 °C
Medium	steam

Description

Steam traps automatically drain condensate without loss of steam or gas. They operate instantaneously and are not affected by backpressure or pressure fluctuations. They do not require an external energy input.

KA 2X is a float-controlled steam trap for all applications and especially suitable for corrosive condensate and applications in the food industry. It is entirely manufactured from stainless steel featuring excellent corrosion resistance. The valve cone is fitted with a metallic seal.

Top and bottom sections of the valve body are connected by a clamp ring and two bolts. Servicing/maintenance is easy and does not call for special tooling.

The simple design makes it easy to specify, install, handle and service these valves in an industrial environment.

Standard

- » all stainless steel construction
- » quick-release body clamp ring
- » manual bleed valve

Options

- » various seal materials suitable for your medium
- » expansion pipe connection in the valve top section for draining condensate from compressed air or gases
- » no manual bleed valve
- » special versions on request

Operating instructions, know how and safety instructions must be observed. All the pressure has always been indicated as overpressure. We reserve the right to alter technical specifications without notice.



Pressure Range [bar]

0 - 13

Flow Rate [l/h]

differential pressure Δp [bar]

0.1	0.2	0.5	1	2	4	6	8	10	12	13
220	320	710	980	1200	1200	1200	1200	1180	1030	950

Steam Traps

Float-controlled Steam Traps KA 2X

Universal Valve for Larger Flow Rates



Materials

Body	CrNiMo-steel
Body Seal	FEPM
Seat, Cone	CrNiMo-steel
Float	CrNiMo-steel
Valve Seal	metallic

Dimensions [mm]

size	inlet female G 1 outlet male G 3/4A	inlet flange DN 25 outlet male G 3/4A
A	140	140
B	145	160
C	40	40
D	200	200

Weights[kg]

inlet female G 1	inlet flange DN 25
2.6	3.5

Customs Tariff Number

84818059

Special designs on request.
The pressure has always been indicated as overpressure.
Mankenberg reserves the right to alter or improve the designs or specifications of the products described herein without notice.

Dimensional Drawing

KA 2X, G 1

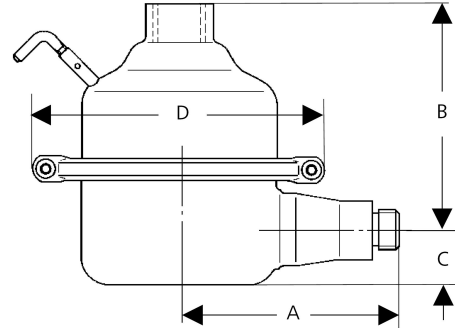

KA 2X, DN 25

