

# Pressure Control Valves

## Pilot-operated Control Valves RP 810 Eck

Pilot-operated Pressure Reducing Valve



### Technical Data

Connection DN	40 - 150
Nominal Pressure PN	16 - 160
Inlet Pressure	up to 160 bar
Outlet Pressure	1 - 40 bar
K <sub>vs</sub> -Value	20 - 250 m <sup>3</sup> /h
Temperature	130 °C
Medium	liquids and gases

### Description

Self-acting pressure reducers are simple control valves offering accurate control while being easy to install and maintain. They control the pressure downstream of the valve without requiring pneumatic or electrical control elements.

The pressure reducing valve RP 810 Eck is a pilot-operated regulating valve consisting of a main valve with a pilot valve fixedly mounted on the cover and a throttle block with integrated strainer, non-return valve and throttle valves. The valve cone is either metallic or soft-sealed.

In a pressureless pipeline the main valve is closed by the pre-tensioned spring.

If the outlet pressure falls below the pre-set nominal value, the pilot valve is kept open by its spring. The control medium flows off towards the valve outlet. Throttle D1 brings about a pressure drop, so that the control pressure in the main valve piston nearly corresponds to the outlet pressure. The inlet pressure overcomes the outlet pressure and the closing spring force and opens the main valve.

Once the outlet pressure has reached the pre-set nominal value, the pilot valve starts to throttle. In doing so, the control pressure rises and pushes the main valve piston to a regulating position. The throttles D1 and D2 serve to optimise the regulating behaviour. The bypass equipped with a non-return valve brings about rapid closure.

If the outlet pressure exceeds the nominal value, the pilot valve closes. The control pressure is equivalent to the inlet pressure. The main valve closes because the piston diameter is larger than the valve seat. In addition, the spring also has a closing effect.

The valve is piped internally. The pulse lines must be installed on-site.

These valves are no shut-off elements ensuring a tight closing of the valve. In accordance with DIN EN 60534-4 and/or ANSI FCI 70-2 they may feature a leakage rate in closed position in compliance with the leakage classes III or V:

Leakage class III (metal sealing cone) = 0.1 % K<sub>vs</sub> value

Leakage class V (soft seal cone) =  $1.8 \times 10^{-5} \times \Delta p \times D^*$  [l/h]

\*D=seat diameter

### Standard

- » pilot valve made of CrNiMo steel
- » throttle block with integrated strainer and throttle valves completely made of CrNiMo steel
- » internal piping made of CrNiMo-steel

### Options

- » damping for gas applications
- » hard-faced valve cone and seat
- » various O-ring and seal materials suitable for your medium
- » special materials such as Duplex, Superduplex, Hastelloy® or titanium, others on request
- » special connections: ANSI or JIS flanges, other connections on request
- » special versions on request

Operating instructions, know how and safety instructions must be observed. All the pressure has always been indicated as overpressure. We reserve the right to alter technical specifications without notice.

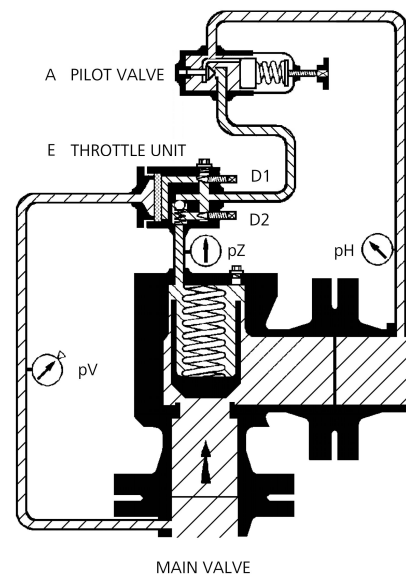
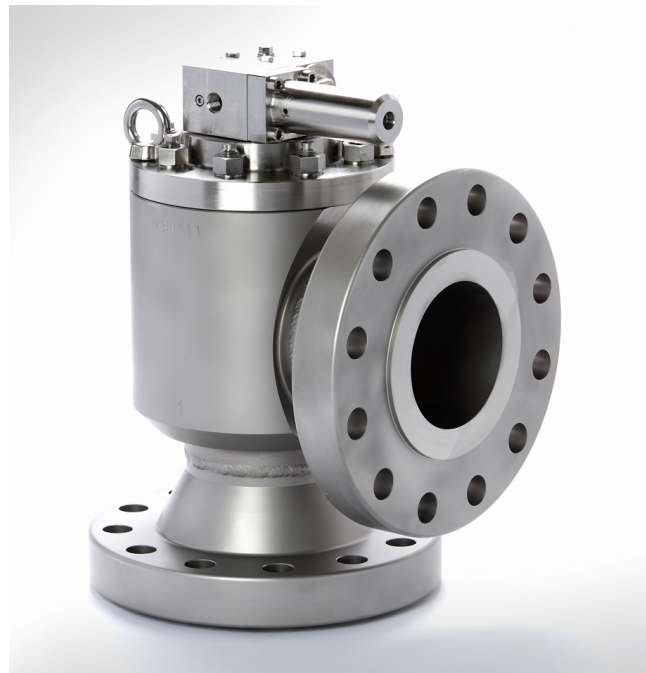

K <sub>vs</sub> Values [m <sup>3</sup> /h]							
nominal diameter DN	40	50	65	80	100	125	150
K <sub>vs</sub> value m <sup>3</sup> /h	20	32	50	60	70	150	250

Pressure Range [bar], Nominal Pressure			
1 - 5	4 - 12	10 - 20	15 - 40
PN 16-160/10	PN 16-160/25	PN 16-160/40	PN 16-160/63

Other pressure ranges on request.

# Pressure Control Valves

## Pilot-operated Control Valves RP 810 Eck

Pilot-operated Pressure Reducing Valve



### Materials

Temperature	80 °C	130 °C
Body	steel optional CrNiMo-steel	
Cover	steel optional CrNiMo-steel	
Internals	Cr-steel optional CrNi-steel or CrNiMo-steel	
Valve Seal	NBR or CrNiMo-steel	EPDM or CrNiMo-steel
O-ring	NBR	EPDM
Pilot Valve	CrNiMo-steel	CrNiMo-steel
Throttle Unit		

### Dimensions [mm]

nominal pressure PN	size	nominal diameter DN						
		40	50	65	80	100	125	150
10 - 16	A	115	125	145	155	175	200	225
25 - 40	A	115	125	145	155	175	200	225
63 - 100	A	130	150	170	190	215	250	275
alle PN	B	200	210	210	230	260	290	300
alle PN	ø C	160	160	180	200	220	280	280

### Weights [kg]

nominal pressure PN	nominal diameter DN						
	40	50	65	80	100	125	150
16 - 40	*	38	44	70	100	*	*
63 - 100	*	45	51	80	110	180	200

### Zolltarifnummer

Customs Tariff Number

Special designs on request.

The pressure has always been indicated as overpressure.

Mankenberg reserves the right to alter or improve the designs or specifications of the products described herein without notice.

### Dimensional Drawing

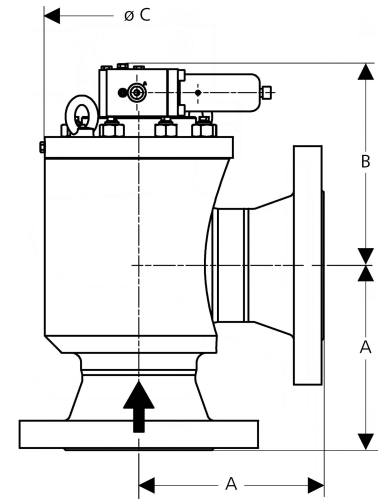

### Recommended Installation

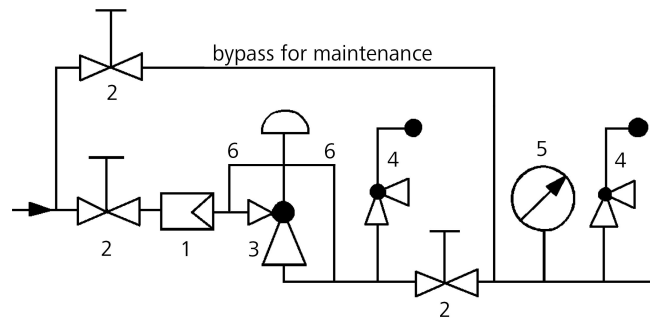

- 1 Strainer
- 2 Shutoff Valves
- 3 Pressure Reducer
- 4 Safety Valve
- 5 Manometer
- 6 Sense Line G 1/2

sense line connection 10 DN before and behind the valve  
use MANKENBERG-Products