

PRECISION FLOW METERS FOR LIQUID APPLICATIONS

10X Series
Microturbine Flow Sensors
Models 101 / 102 / 104 / 107



APPLICATION IDEAS

- Monitoring coolant and lubricants
- Totalizing chemical injection streams
- Water and wastewater treatment measurements
- Upgrading rotameters to monitor flow rate

Product Description

McMillan 10X Series Flow Sensors are capable of measuring extremely low flow rates. Units are available that measure liquids as low as 13 mL/minute and as high as 50 L/minute. Full scale accuracies of $\pm 1.0\%$ or better are available on select models.

A wide variety of liquids may be measured. Repeatable results are achieved using a patented Pelton-type microturbine wheel. This proven design has been providing precision results since 1988 and has developed a well-deserved reputation for continuous operational service for many years without failure.

Because of the compact size and economical cost of these products, the 10X Series Flow Sensors are suitable for a wide variety of industrial, commercial, laboratory and O.E.M. applications. Some sample applications include measurement of hydrocarbon fluids, fuels, light oils, solvents, coolant, pesticides, mild acids, alkalis, and deionized water. Several power and output configurations are available, including both pulse and analog outputs. NIST Traceable certificates are available on most models.

Principle of Operation

McMillan's microturbine wheel technology utilizes the Pelton turbine wheel concept. This design allows for use of a miniature turbine wheel. The wheel is supported on a very small sapphire shaft, held in position by two maintenance-free bearings. Due to the light weight of both the wheel and the shaft, the microturbine wheel is virtually suspended in the flow path. This suspension effect relieves force on the shaft and bearings, eliminating wear.

As flow passes through the flow sensor, it is directed onto the very small teeth of the wheel using a precision-machined nozzle. (as shown with blue arrows in Figure 1) This nozzle is sized according to the flow range of the unit. The rotational speed of the turbine wheel increases proportionally to the volumetric flow rate.

The microturbine wheel (see Figure 1) has alternating white and black sections evenly spaced on one surface of the wheel. As the wheel rotates (as shown with green arrows), an infrared beam (as shown with red arrows) is reflected off each white section and directed to a phototransistor which detects each reflected beam and converts them into measured pulses.

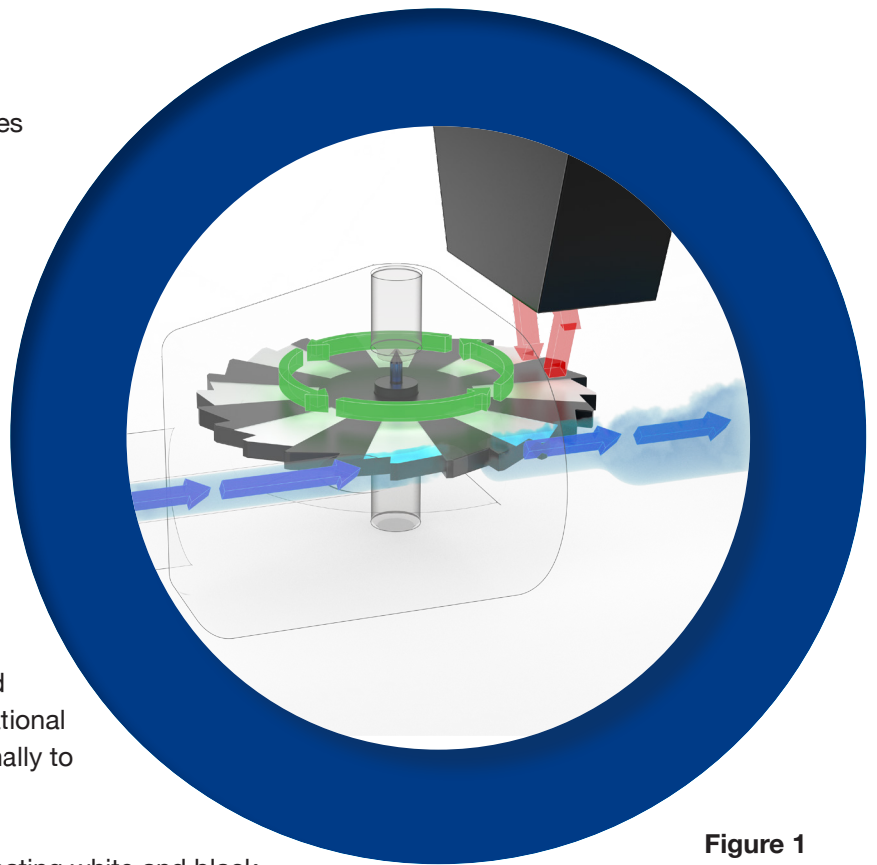

Figure 1
Representation of
microturbine technology

Features and Options

FLOW RANGES*

Units are available that measure liquids as low as 13 mL/minute and as high as 50 L/minute.

POWER

Most units may be specified to operate with either 12 VDC or 24 VDC power. Various power adapters are also available for use with 12 VDC versions.

SIGNAL OUTPUTS

Most units may be ordered with a 0-5 VDC output, a pulse output, or with both. The Model 107 is only available with a 4-20 mA output.

ACCURACY/LINEARITY

Standard accuracy specification of $\pm 1\%$ F.S. including linearity. An improved accuracy specification of $\pm 0.5\%$ is available on some models. NIST traceable calibration certificates are standard for improved accuracy ("H") models and optional for standard units.

FLUID CONNECTIONS

Units feature compression tube fittings. Alternate fitting types and sizes may be selected as noted in the Fitting Codes Chart.

ELECTRICAL CONNECTIONS

All models have an integrated 4-pin male connector. To complete connections, either a cable assembly or power adapter should be ordered.

WETTED MATERIALS

The wetted materials vary depending on the model number. See the specifications for further details.

DISPLAYS*

A number of remote displays are also available for use with any flow sensor and flow meter. Please request further information from the factory.



*Consult the factory or an authorized representative for additional information.

Specifications

Except where noted all specifications apply to operation at +25°C

Flow Performance & Hardware

	101	102	104	107
Accuracy (including linearity, best fit straight line)	Analog Output: $\pm 1.0\%$ Full Scale "H" Option (Analog Output): $\pm 0.5\%$ Full Scale Pulse Output: $\pm 3.0\%$ Full Scale			Analog Output: $\pm 1.0\%$ Full Scale
Repeatability	$\pm 0.2\%$ Full Scale			
Pressure Rating	100 psig (6.8 bar)	500 psig (34 bar)		
Temperature Rating	Operating Range: 5 - 55°C Storage Range: 0 - 70°C			
Temperature Sensitivity	$\pm 0.2\%$ F.S. or less per °C			
Wetted Materials	PPS 304 SS Epoxy Glass Sapphire FKM Acetal (fittings)	Brass PPS 316L SS 303 SS Epoxy Glass Sapphire FKM	316L SS 303 SS Epoxy Glass Sapphire FKM	316L SS 303 SS Epoxy Glass Sapphire FKM
Recommended Filtration	25 microns or less			
Compatible Media	Low viscosity (<15 cS), translucent or transparent, degassed			
0-5 VDC Output Signal	Non-isolated, 2500 ohm minimum load			Not available
Pulse Output Signal	7.5VDC peak buffered square wave 0-400 Hz typical			Not available
4-20 mA Output Signal	Not available			Non-isolated, current loop should not exceed 500 ohms
Power	12 VDC units: 11.5 to 15 VDC @ 35 mA 24 VDC units : 22 to 25 VDC @ 35 mA			22 to 25 VDC @ 65 mA
Response Time	Typically <1 second to 67% of final value			
Certifications	CE Approved 89 / 336 / EEC (EN 55011 & EN 50082-1) 73 / 23 / EEC Low Voltage Directive UKCA			
Ratings	IP10 (NEMA 1)			
Warranty	1 Year Limited			

Ordering Information

Form part number as follows:

(Base Model) - (Flow Range) (Power/Signal) - (Cable/Connector) - (Fittings) - (Options)

Example: 104-6T-CM-S4-H

10 - - - - CM - - - -

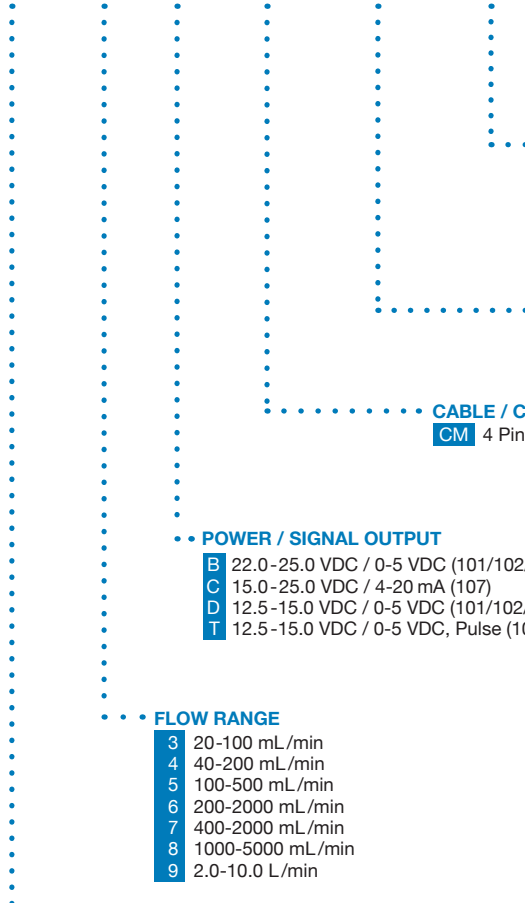

OPTIONS

H Improved $\pm 0.5\%$ F.S. Accuracy (ranges 3-8 only), includes NIST
NIST NIST Certificate (water only). Contact factory or an authorized representative for calibrations of other media

FITTINGS (SEE FITTING AVAILABILITY CHART BELOW FOR AVAILABLE SIZES BASED ON FLOW RANGE)

- A2** 1/8" acetal
- A4** 1/4" acetal
- A6** 3/8" acetal
- B2** 1/8" brass
- B4** 1/4" brass
- B6** 3/8" brass
- S2** 1/8" 316L stainless steel
- S4** 1/4" 316L stainless steel
- S6** 3/8" 316L stainless steel

POWER / SIGNAL OUTPUT

- B** 22.0-25.0 VDC / 0-5 VDC (101/102/104)
- C** 15.0-25.0 VDC / 4-20 mA (107)
- D** 12.5-15.0 VDC / 0-5 VDC (101/102/104)
- T** 12.5-15.0 VDC / 0-5 VDC, Pulse (101/102/104)

FLOW RANGE

- 3** 20-100 mL/min
- 4** 40-200 mL/min
- 5** 100-500 mL/min
- 6** 200-2000 mL/min
- 7** 400-2000 mL/min
- 8** 1000-5000 mL/min
- 9** 2.0-10.0 L/min

MODEL

- 101** Plastic microturbine flow sensor for liquids
- 102** Brass microturbine flow sensor for liquids
- 104** Stainless steel microturbine flow sensor for liquids
- 107** Stainless steel microturbine flow sensor for liquids

FITTING AVAILABILITY									
	101			102			104/107		
CODE	A2	A4	A6	B2	B4	B6	S2	S4	S6
SIZE	1/8"	1/4"	3/8"	1/8"	1/4"	3/8"	1/8"	1/4"	3/8"
MATERIAL	ACETAL			BRASS			316L SS		
RANGE 3	✓	✓		✓	✓	✓	✓	✓	✓
RANGE 4		✓			✓	✓		✓	✓
RANGE 5		✓			✓	✓		✓	✓
RANGE 6		✓	✓		✓	✓		✓	✓
RANGE 7		✓	✓		✓	✓		✓	✓
RANGE 8			✓		✓	✓		✓	✓
RANGE 9			✓		✓	✓		✓	✓

EXAMPLE

104-6T-CM-S4-H would provide a stainless steel-bodied microturbine flow sensor with both an analog 0-5 VDC and pulse outputs, requires 12 VDC power, includes 1/4" stainless steel tube fittings, is calibrated to $\pm 0.5\%$ linearity (full scale), and measures flow rates from 100 to 1,000 mL/minute.

Dimensions

Basic unit configurations shown. Contact factory or an authorized representative for dimensions of units not shown. All dimensions shown in inches [mm] unless otherwise noted.

101:

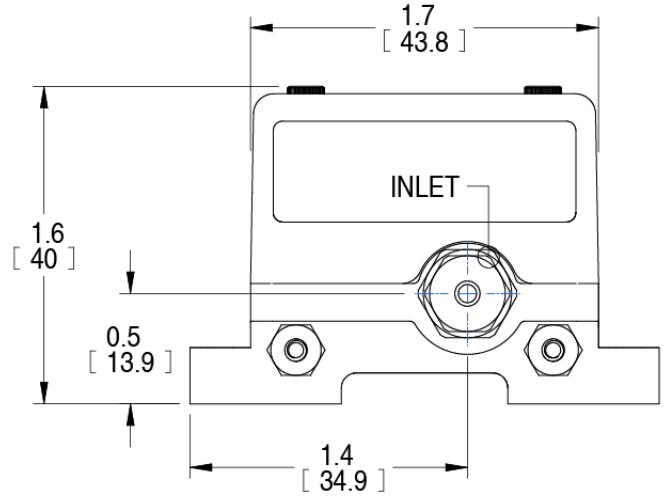
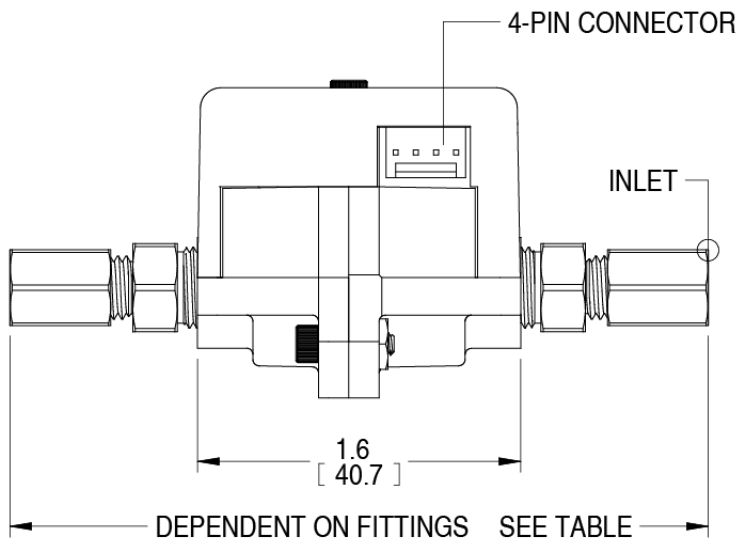

OVERALL LENGTH TABLE			
FITTING	A2	A4	A6
LENGTH	3.5 (87.9)	3.9 (99.3)	4.4 (111.5)

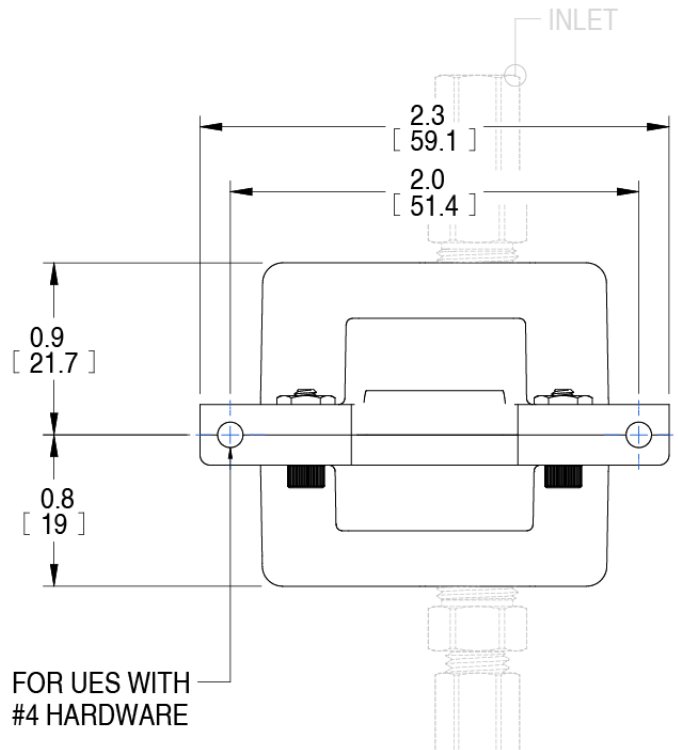

Dimensions

Basic unit configurations shown. Contact factory or an authorized representative for dimensions of units not shown. All dimensions shown in inches [mm] unless otherwise noted.

102 / 104 / 107:

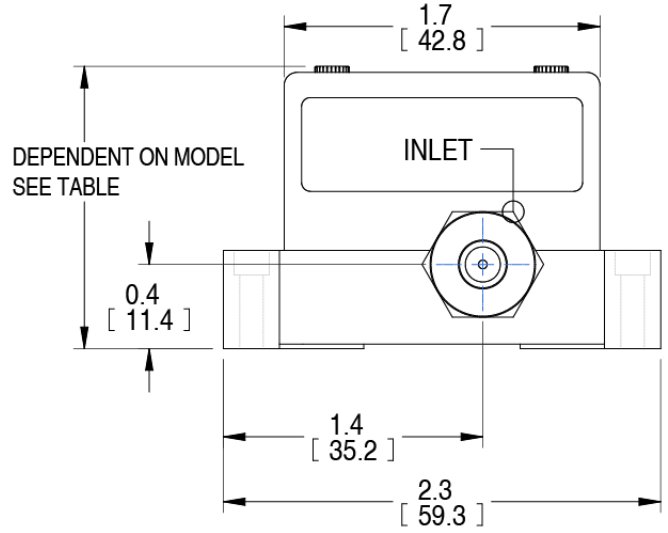
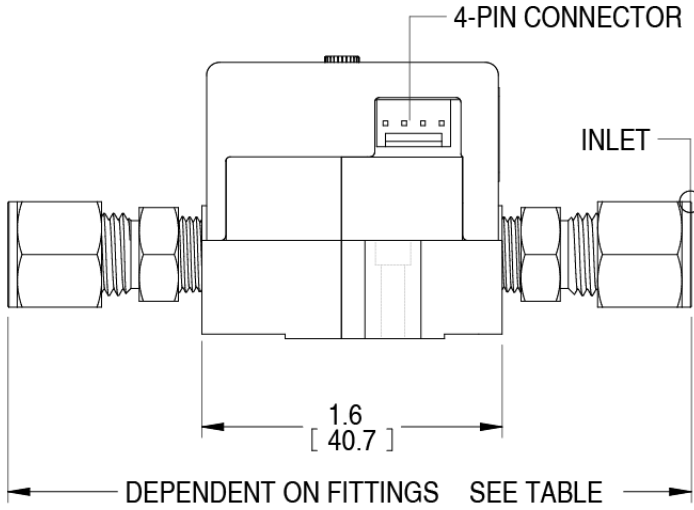

OVERALL LENGTH TABLE			
FITTING	B2 / S2	B4 / S4	B6 / S6
LENGTH	3.45 (87.6)	3.65 (92.7)	3.83 (97.3)

OVERALL HEIGHT TABLE		
MODEL CODE	102 / 104	107
HEIGHT	1.5 (38.3)	2.2 (56.3)

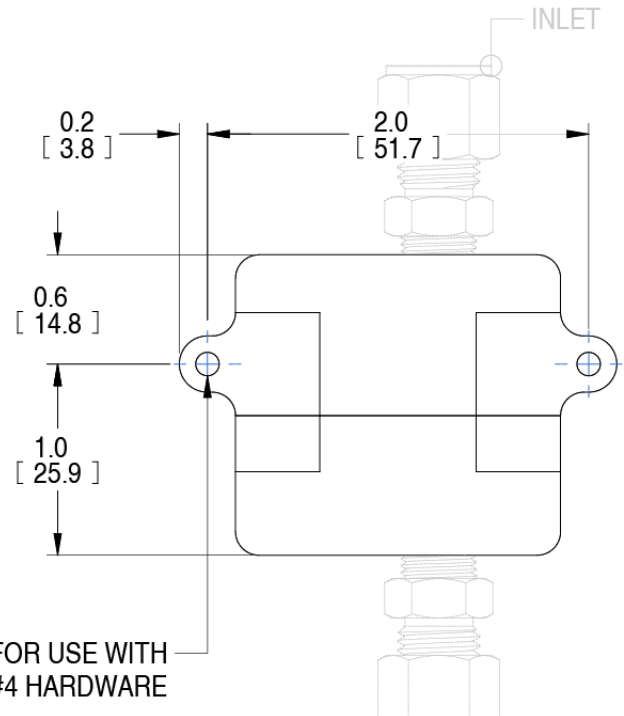

Related Accessories (Models 101 / 102 / 104)

CODE	DESCRIPTION
100-17T	Mating cable for CM option with pigtail leads (36" length)
110-00-08T	115 VAC power adapter, includes signal cable
110-00-18T	230 VAC power adapter, includes signal cable

Related Products

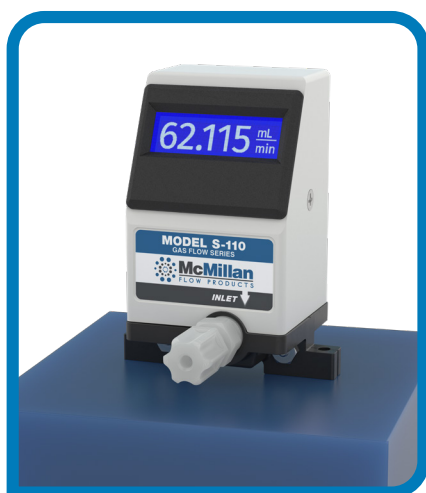

S Series Flow Meters

Flow meters with integrated flow rate display



Model 250 Display

Multifunction display for use with the 10X



106 Series Flow Meters

Microturbine flow sensors for liquid applications



McMillan Flow Products
P.O. Box 1340
Georgetown, Texas 78627
Toll-Free: (800) 861-0231 (U.S.A. only)
Direct: +1 (512) 863-0231
Email: sales@mcmflow.com
Website: www.mcmflow.com