

Compact Direct Operated 2/3 Port Solenoid Valve for Chemicals

Series LVM



★Wetted part material:

Body/Plate

PEEK

Diaphragm

Choice of

EPDM, FKM, Kalrez® (Note)

★Service life: **10** million cycles or more
(Based on SMC test conditions)

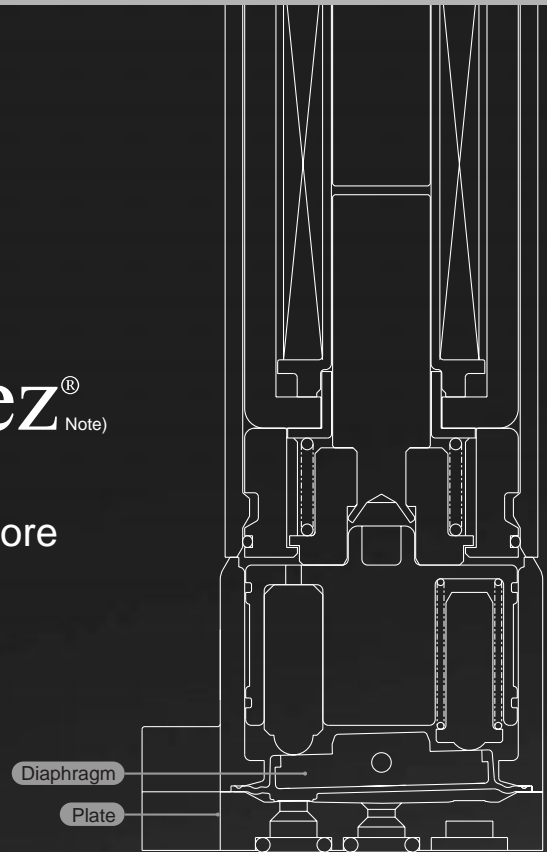

Diaphragm
Plate

More variations!

Orifice diameter
1.1 mm



LVM09/090

Orifice diameter
1.4 mm



LVM10/100

Orifice diameter
1.6 mm



LVM15/150

Orifice diameter
2 mm



LVM20/200

VX2

VXD

VXZ

VXE

VXP

VXR

VXH

VXF

VX3

VXA

VCH□

VDW

VQ

LVM

VCA

VCB

VCL

VCS

VCW

Note) Kalrez® is a registered trademark of DuPont Performance Elastomers.

Meeting the most advanced needs of process control

Compact Direct Operated 2/3 Port

Solenoid Valve for Chemicals

○ Valve chamber volume

Unit: μl

Series	LVM09/090	LVM10 (For LVM11)	LVM10/100	LVM15/150	LVM20/200
Valve chamber volume	18	11	20	50	84

○ Change in volume depending on open/closed status of valve (pumping volume)

0.01 μl or less (Rocker type)

"Pumping volume" refers to the volume of water that is expelled from the valve chamber, in which it is sealed, by the opening and closing action of the valve (once with no applied pressure).

With a normal diaphragm valve, because the valve chamber volume varies depending on ON or OFF status, a difference in volume is discharged into the outlet side of the valve when the valve is switched from ON to OFF. However, with a rocker type valve, there is almost no change in volume, and thus no fluid is discharged into the outlet side of the valve.

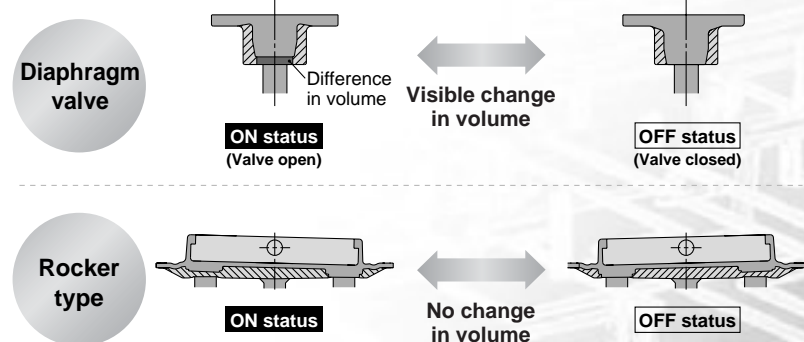

○ Type with power-saving circuit can be selected.

Holding power consumption can be reduced substantially.

Unit: W

Series	LVM09/090	LVM10/100	LVM15/150	LVM20/200	
Power consumption	Inrush	3.3	2.5	5.5	4
	Holding	0.9	1	1	0.6

○ Space-saving

Unit: mm

Series	LVM090	LVM10/100	LVM150	LVM200
Valve width	9.5	13	16	20
Manifold pitch	10.5	14	17	21

Refer to 10 in "Design and Selection" on the back of page 302, if the valve is to be energized continuously for extended periods of time, or used with a manifold.

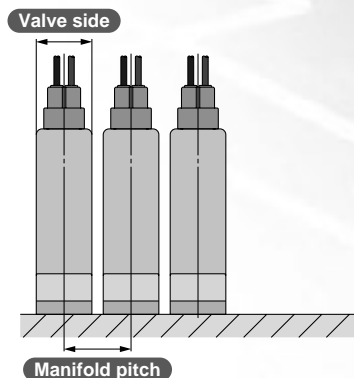

○ Applications: Various analytical and inspection equipment

Analytical instruments for blood, urine, immune system, etc.

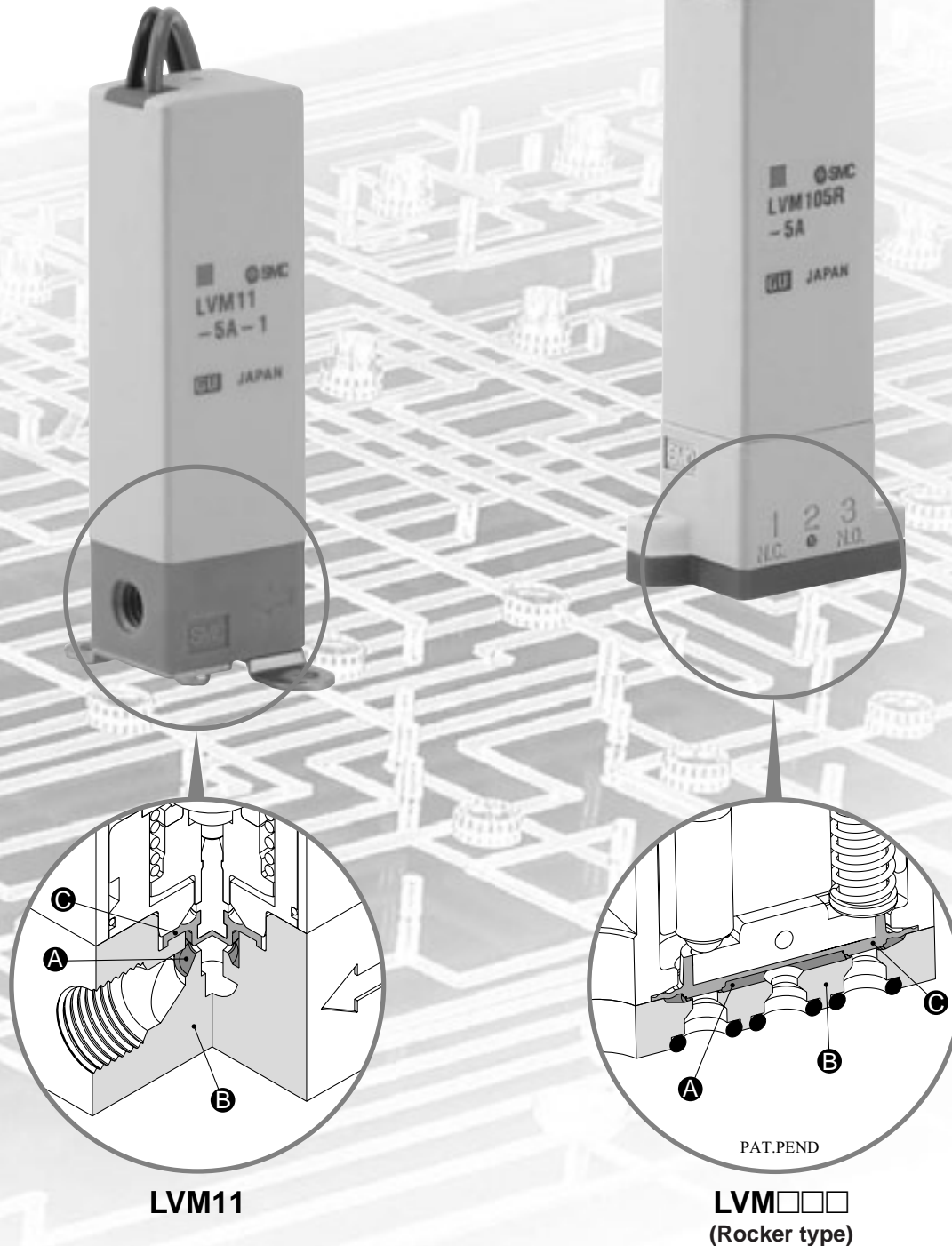

- A** Valve chamber volume
- B** Body/Plate material: PEEK
- C** Diaphragm material: EPDM, FKM or Kalrez®

Piping/Mounting Variations

Body ported

• M5 thread

• Tubing type

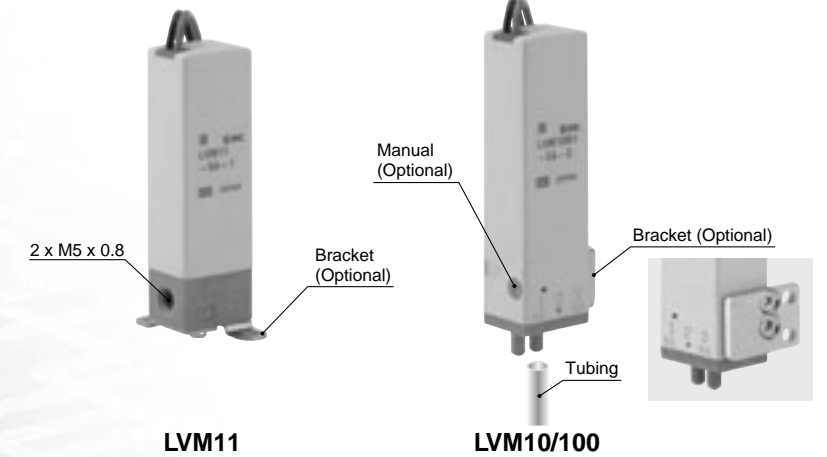

Base mounted



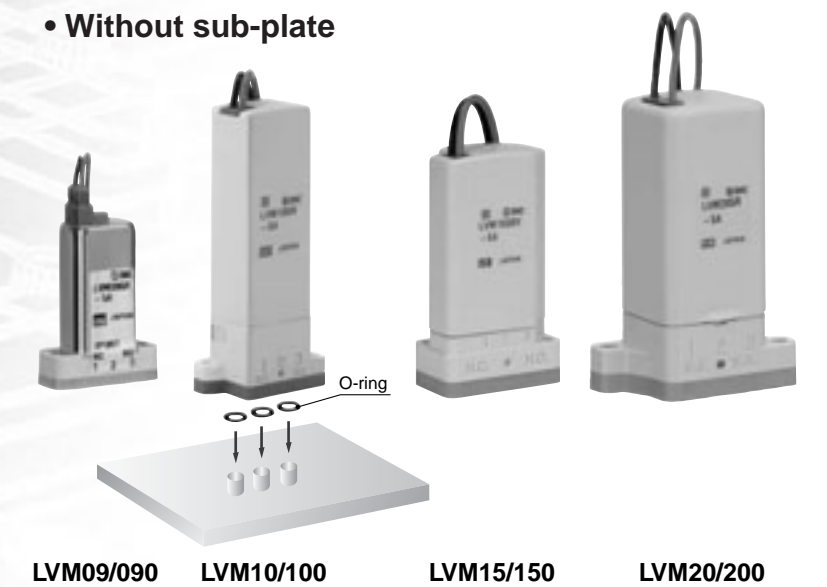



• Without sub-plate



• With sub-plate



- VX2
- VXD
- VXZ
- VXE
- VXP
- VXR
- VXH
- VXF
- VX3
- VXA
- VCH
- VDW
- VQ
- LVM**
- VCA
- VCB
- VCL
- VCS
- VCW

	Model	Valve construction	Valve type	Number of ports	Operating pressure range	Orifice diameter (mm)	Valve width	Flow characteristics				Fluid temperature (°C)	Volume of valve chamber	Mass (g)	Power consumption (W)	Page
								Water		Air						
								Av	Cv	C	b					
	LVM09R3	Diaphragm type direct operated poppet (Rocker type)	N.C.	2	-75 kPa to 0.2 MPa	1.1	9.5	0.43 x 10 ⁻⁶	0.018	0.06	0.2	18	20	2	P.286 to 288	
	LVM09R4		N.O.													
	LVM095R		Universal	3												
	LVM11	Diaphragm type direct operated poppet	N.C.	2	0 to 0.25 MPa	1.5	13	0.96 x 10 ⁻⁶	0.04	0.13	0.22	11	30	2.5 at inrush 1 at holding	P.289 to 293	
	LVM10R1	Diaphragm type direct operated poppet	N.C.	2	-75 kPa to 0.25 MPa	1.4	13	0.72 x 10 ⁻⁶	0.03	0.1	0.2	20	34	1.5	P.289 to 295	
	LVM10R2		N.O.													
	LVM102R		Universal	3												
	LVM10R3	Diaphragm type direct operated poppet (Rocker type)	N.C.	2	-75 kPa to 0.25 MPa	1.4	13	0.72 x 10 ⁻⁶	0.03	0.1	0.2	20	34	1.5	P.289 to 295	
	LVM10R4		N.O.													
	LVM10R6		N.C.													
	LVM105R		Universal	3												
	LVM15R3	Diaphragm type direct operated poppet (Rocker type)	N.C.	2	-75 kPa to 0.25 MPa (0 to 0.6 MPa)	1.6 (1)	16	0.96 x 10 ⁻⁶ (0.36 x 10 ⁻⁶)	0.04 (0.015)	0.13 (0.05)	0.22 (0.2)	50	45	5.5 at inrush 1 at holding	P.296 to 298	
	LVM15R4		N.O.													
	LVM155R		Universal	3												
	LVM20R3	Diaphragm type direct operated poppet (Rocker type)	N.C.	2	-75 kPa to 0.3 MPa	2	20	1.56 x 10 ⁻⁶	0.065	0.23	0.27	84	80	2.5	P.299 to 301	
	LVM20R4		N.O.													
	LVM205R		Universal	3												

- VX2
- VXD
- VXZ
- VXE
- VXP
- VXR
- VXH
- VXF
- VX3
- VXA
- VCH□
- VDW
- VQ
- LVM**
- VCA
- VCB
- VCL
- VCS
- VCW

The figures in () indicate the high-pressure type.

* The values of Av and Cv are based on JIS B 2005:1995, C and b are based on JIB B 8390:2000.

Compact Direct Operated 2/3 Port Solenoid Valve for Chemicals Series *LVM09/090*

How to Order

Base Mounted

LVM 09R3 - 5 A - -



Symbol	Number of ports	Valve type	
09R3	2	N.C.	
09R4		N.O.	
095R	3	Universal	

Symbol

Lead wire length

Nil	150 mm
3	300 mm
6	600 mm

* Nil cannot be selected in the case of function Y1.

CE compliant

Nil	None
Q	CE compliant

Wetted part material

Symbol	Plate	Diaphragm
A	PEEK	EPDM
B	PEEK	FKM
C	PEEK	Kalrez®

Coil voltage

Symbol	Voltage
5	24 VDC
6	12 VDC

Function

Nil	Standard
Y1	With power-saving circuit

Specifications

Model	Base mounted		
	LVM09R3	LVM09R4	LVM095R
Valve construction	Diaphragm type direct operated poppet (Rocker type)		
Valve type	N.C.	N.O.	Universal
Number of ports	2		3
Fluid ^{Note 1)}	Air, Water, Pure water, Diluent, Cleaning fluid		
Operating pressure range	-75 kPa to 0.2 MPa		
Orifice diameter	1.1 mm		
Response time	10 ms or less (at pneumatic pressure)		
Leakage	Zero leakage, either external or internal (at water pressure)		
Proof pressure ^{Note 2)}	0.3 MPa		
Ambient temperature	0 to 50°C		
Fluid temperature	0 to 50°C (No condensation)		
Volume of valve chamber ^{Note 3)}	18 μl		
Mounting orientation ^{Note 4)}	Free		
Enclosure	IP40 or equivalent		
Mass	20 g		
Rated voltage	12, 24 VDC		
Allowable voltage fluctuation ^{Note 5)}	±10% of rated voltage		
Type of coil insulation	Class B		
Power consumption (When rated voltage is at 24 V)	Standard		2 W (0.08 A)
	With power-saving circuit	Inrush	3.3 W (0.14 A)
		Holding	0.9 W
Coil switching noise ^{Note 6)}	50 dB		

Note 1) Select an appropriate material for the wetted part when fluid such as a cleaning solvent is used. Also, be sure to confirm the fluid compatibility in advance.

Note 2) Indicates the pressure which does not generate breakage, cracks or external leakage after a one-minute airtight test.

Note 3) Indicates the volume of clearance inside the valve chamber after the volume of the diaphragm is subtracted.

Note 4) Since the body (orifice shape) is designed to eliminate residual liquid, mounting in a vertical direction with the coil at the top is recommended. When residual liquid is not considered, any mounting orientation is available.

Note 5) When the response speed is regarded as important, prevent negative fluctuation of the voltage by adequate regulation.

Note 6) The value is based on SMC's measurement conditions. The noise level will vary with conditions.

Note 7) Refer to 10 in "Design and Selection" on the back of page 302, if the valve is to be energized continuously for extended periods of time.

Flow Characteristics

Water		Air	
Av	Cv	C	b
0.43 x 10 ⁻⁶	0.018	0.06	0.2

* The values of Av and Cv are based on JIS B 2005:1995, C and b are based on JIB B 8390:2000.

Construction: Base Mounted

LVM09R3

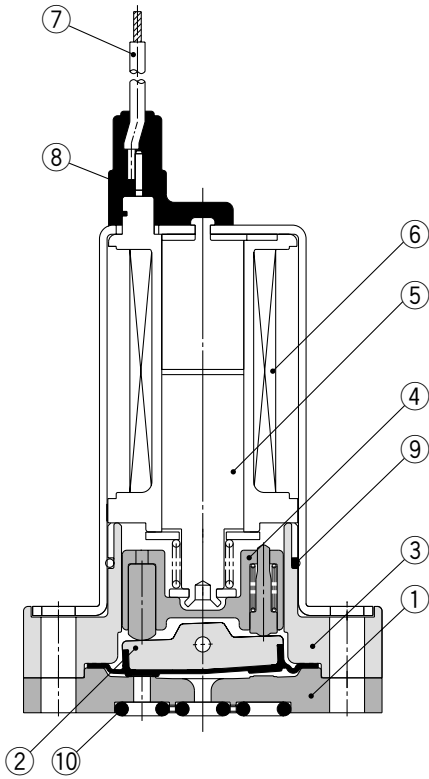

LVM09R4

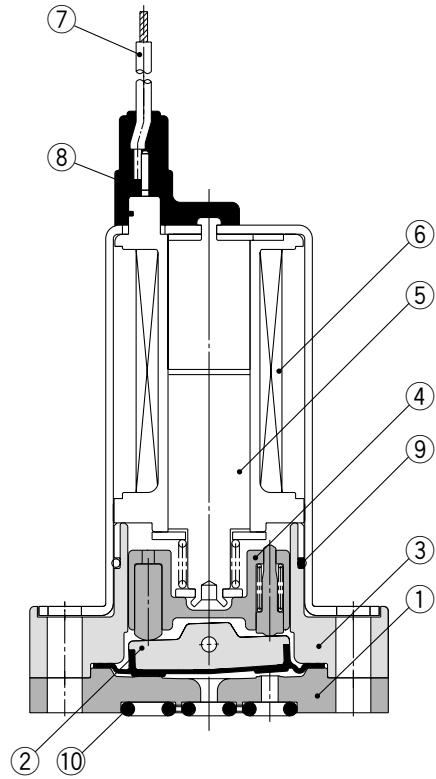

LVM095R

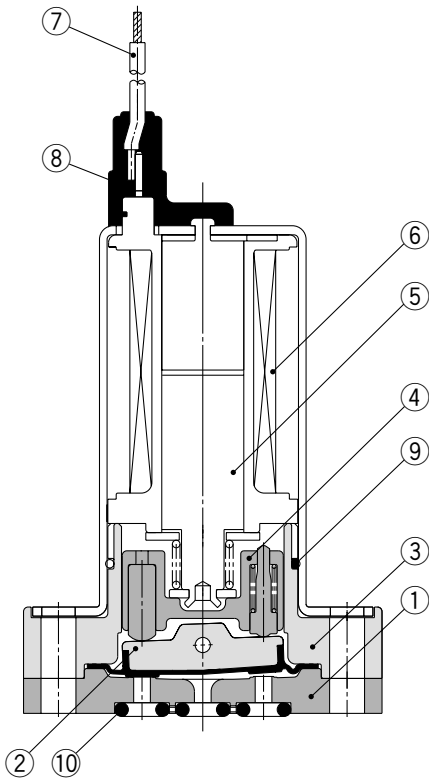

- VX2
- VXD
- VXZ
- VXE
- VXP
- VXR
- VXH
- VXF
- VX3
- VXA
- VCH□
- VDW
- VQ
- LVM**
- VCA
- VCB
- VCL
- VCS
- VCW

Component Parts: LVM09R3, 09R4, 095R

No.	Description	Material
1	Plate	PEEK
2	Diaphragm assembly	EPDM/FKM/Kalrez®
3	Body	PBT
4	Slide bushing assembly	PPS/Stainless steel
5	Armature assembly	—
6	Coil assembly	—
7	Lead wire	—
8	Mold	PET
9	O-ring	NBR
10	Interface gasket	EPDM/FKM/Kalrez®

Series LVM09/090

Dimensions: Base Mounted

LVM09R3
LVM09R4
LVM095R

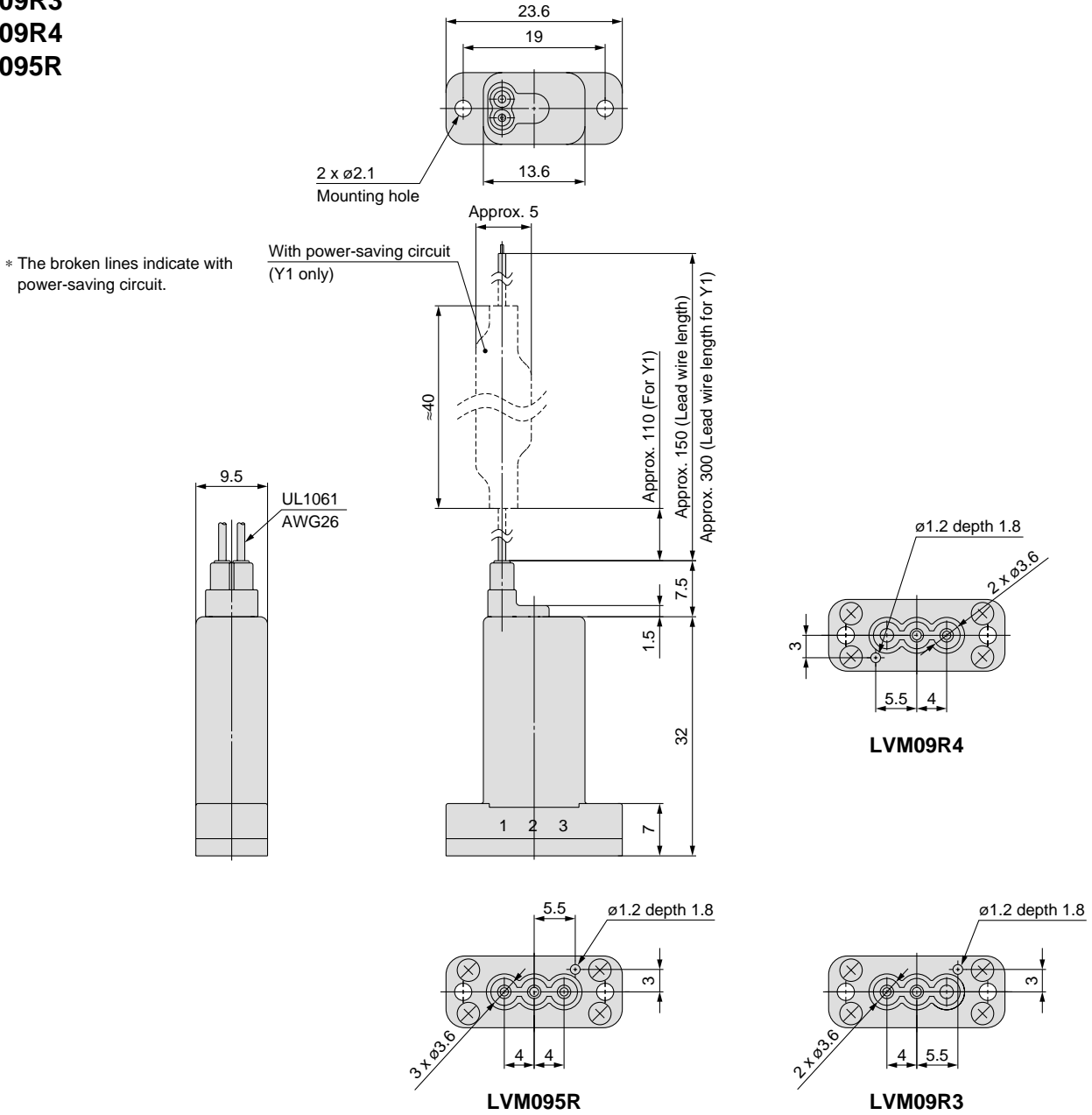

Recommended interface dimensions

* Surface roughness = Rz3.2 or less

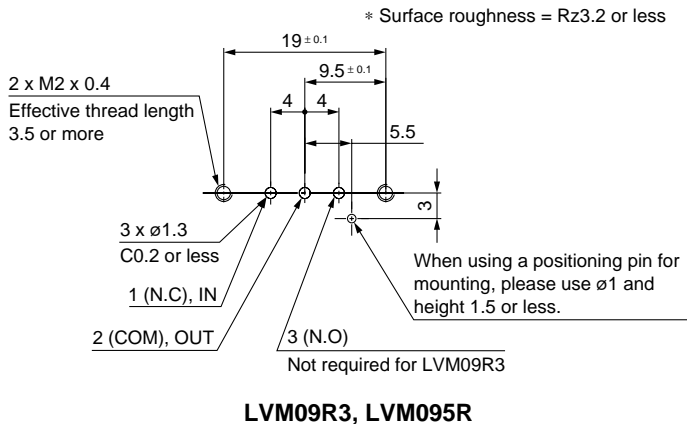

When using a positioning pin for mounting, please use $\phi 1$ and height 1.5 or less.

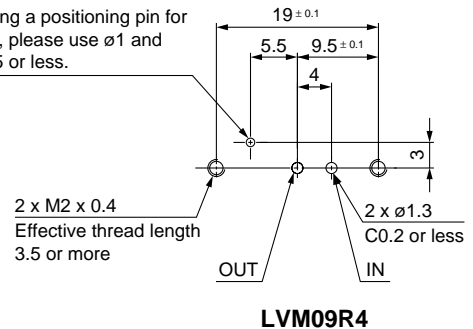

Compact Direct Operated 2/3 Port Solenoid Valve for Chemicals

Series LVM10/100

How to Order

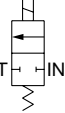
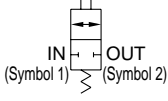
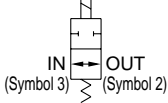
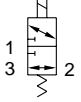
Symbol	Number of ports	Valve type	Connection
11		N.C. 	M5 thread
10R1	2	N.C. 	Tubing type
10R2		N.O. 	
102R	3	Universal 	

Wetted part material

Symbol	Plate	Diaphragm
A	PEEK	EPDM
B	PEEK	FKM
C	PEEK	Kalrez®

Option

Nil	None
1	Bracket
2	Manual override
3	Bracket, Manual override

* Only Option 1 can be selected for the LVM11

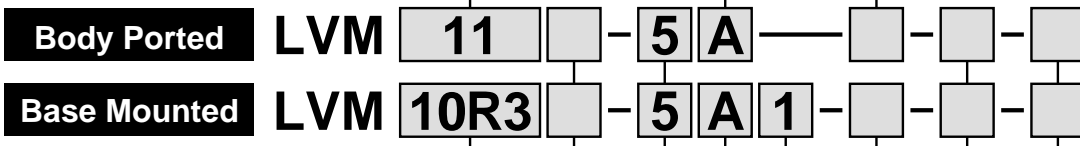

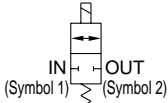
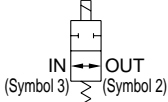
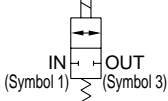
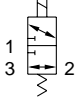
Symbol	Number of ports	Valve type
10R3		N.C. 
10R4	2	N.O. 
10R6		N.C. 
105R	3	Universal 

Function

Nil	Standard
Y	With power-saving circuit

* For the LVM11, the type with power-saving circuit is standard.

Coil voltage

Symbol	Voltage
5	24 VDC
6	12 VDC

Wetted part material

Symbol	Plate	Diaphragm
A	PEEK	EPDM
B	PEEK	FKM
C	PEEK	Kalrez®
E	PFA	EPDM
F	PFA	FKM
G	PFA	Kalrez®

CE compliant

Nil	None
Q	CE compliant

Lead wire length

Nil	300 mm
6	600 mm
10	1000 mm

Option

Nil	None
1	Bracket
2	Manual override
3	Bracket, Manual override

* Without a sub-plate, a bracket cannot be attached.

Sub-plate material/Port size

Nil	Without sub-plate	
1*	PVDF	M6
1U*	PVDF	1/4-28UNF
2	PFA	M6
2U	PFA	1/4-28UNF

* Combinations with wetted part materials E, F, G. are not available.

- VX2
- VXD
- VXZ
- VXE
- VXP
- VXR
- VXH
- VXF
- VX3
- VXA
- VCH
- VDW
- VQ
- LVM
- VCA
- VCB
- VCL
- VCS
- VCW

Series LVM10/100

Specifications



Body ported



Body ported
(Tubing type)



Base mounted
(Without sub-plate)



Base mounted
(With sub-plate)

Model	Body ported	Body ported (Tubing type)			Base mounted			
	LVM11	LVM10R1	LVM10R2	LVM102R	LVM10R3	LVM10R4	LVM10R6	LVM105R
Valve construction	Diaphragm type direct operated poppet	Diaphragm type direct operated poppet (Rocker type)						
Valve type	N.C.	N.C.	N.O.	Universal	N.C.	N.O.	N.C.	Universal
Number of ports	2	2		3	2		3	
Fluid ^{Note 1)}	Air, Water, Pure water, Diluent, Cleaning fluid							
Operating pressure range	0 to 0.25 MPa	-75 kPa to 0.25 MPa						
Orifice diameter	1.5 mm	1.4 mm						
Response time	10 ms or less (at pneumatic pressure)							
Leakage	Zero leakage, either external or internal (at water pressure)							
Proof pressure ^{Note 2)}	0.38 MPa							
Ambient temperature	0 to 50°C							
Fluid temperature	0 to 50°C (No condensation)							
Volume of valve chamber ^{Note 3)}	11 μℓ	20 μℓ						
Mounting orientation ^{Note 4)}	Free							
Enclosure	IP40 or equivalent							
Mass	30 g	34 g (without sub-plate), 42 g (with sub-plate)						
Rated voltage	12, 24 VDC							
Allowable voltage fluctuation ^{Note 5)}	±10% of rated voltage							
Type of coil insulation	Class B							
Power consumption (When rated voltage is at 24 V)	Standard	—		1.5 W (0.06 A)				
	With power-saving circuit	In-rush	2.5 W (0.1 A)					
		Hold-ing ^{Note 6)}	1 W					
Coil switching noise ^{Note 6)}	50 dB							

Note 1) Select an appropriate material for the wetted part when fluid such as a cleaning solvent is used. Also, be sure to confirm the fluid compatibility in advance.

Note 2) Indicates the pressure which does not generate breakage, cracks or external leakage after a one-minute airtight test.

Note 3) Indicates the volume of clearance inside the valve chamber after the volume of the diaphragm is subtracted.

Note 4) Since the body (orifice shape) is designed to eliminate residual liquid, mounting in a vertical direction with the coil at the top is recommended. When residual liquid is not considered, any mounting orientation is available.

Note 5) When the response speed is regarded as important, prevent negative fluctuation of the voltage by adequate regulation.

Note 6) The value is based on SMC's measurement conditions. The noise level will vary with conditions.

Note 7) Refer to 10 in "Design and Selection" on the back of page 302, if the valve is to be energized continuously for extended periods of time.

Flow Characteristics

Valve construction	Water		Air	
	Av	Cv	C	b
Direct operated poppet	0.96 x 10 ⁻⁶	0.04	0.13	0.22
Rocker type	0.72 x 10 ⁻⁶	0.03	0.1	0.2

* The values of Av and Cv are based on JIS B 2005:1995, C and b are based on JIB B 8390:2000.

Construction: Body Ported

LVM11

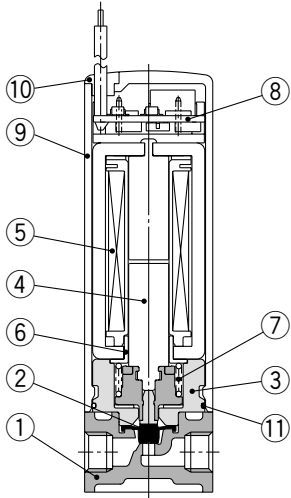

Component Parts: LVM11

No.	Description	Material
1	Body	PEEK
2	Diaphragm assembly	EPDM/FKM/Kalrez®
3	Spacer	PBT
4	Armature assembly	Stainless steel/POM
5	Coil assembly	—
6	Sleeve	SUY
7	Return spring	Stainless steel
8	Board assembly	—
9	Casing	PBT
10	Plug	NBR
11	O-ring	NBR

LVM10R1

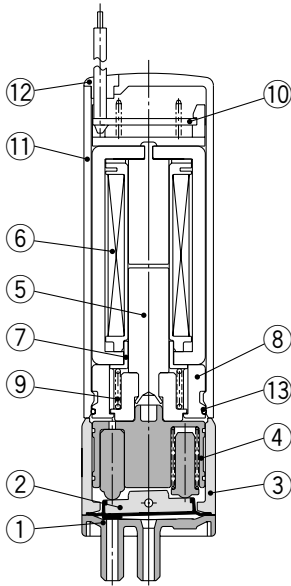

LVM10R2

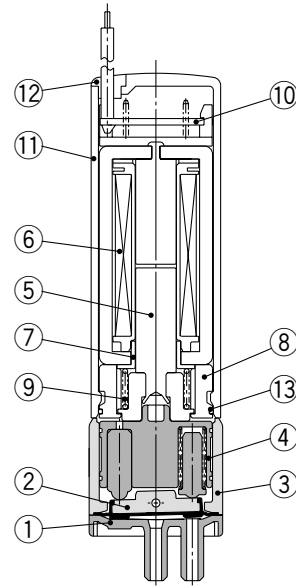

LVM102R

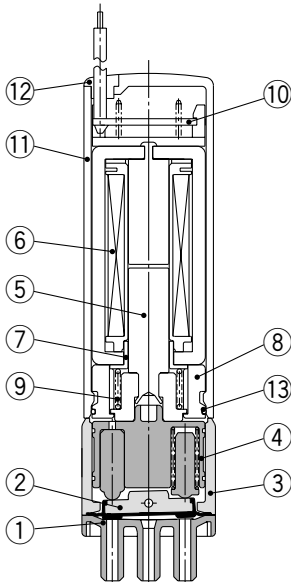

Component Parts: LVM10R1, 10R2, 102R

No.	Description	Material
1	Plate	PEEK
2	Diaphragm assembly	EPDM/FKM/Kalrez®
3	Body	PBT
4	Slide bushing assembly	POM/Stainless steel
5	Armature assembly	Stainless steel/PBT
6	Coil assembly	—
7	Sleeve	SUY
8	Spacer	PBT
9	Return spring	Stainless steel
10	Board assembly	—
11	Casing	PBT
12	Plug	NBR
13	O-ring	NBR

VX2

VXD

VXZ

VXE

VXP

VXR

VXH

VXF

VX3

VXA

VCH□

VDW

VQ

LVM

VCA

VCB

VCL

VCS

VCW

Series LVM10/100

Construction: Base Mounted

LVM10R3

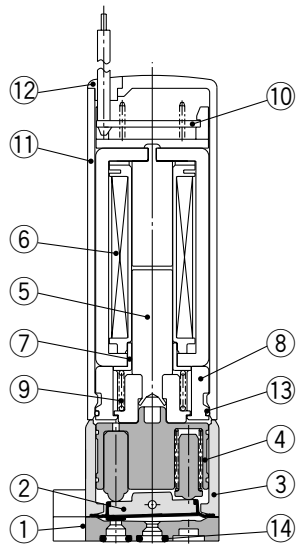

LVM10R4

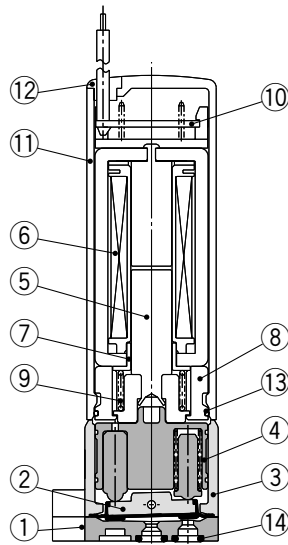

LVM10R6

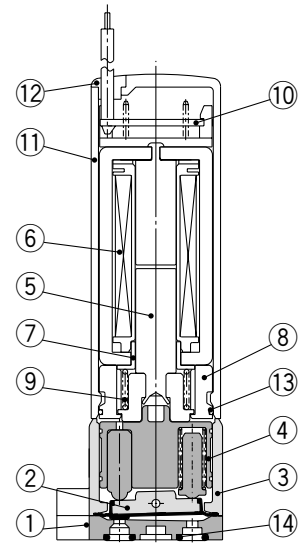

LVM105R

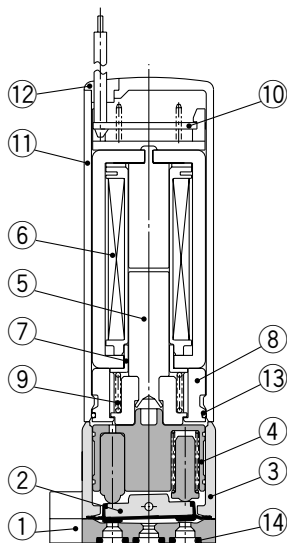

Component Parts: LVM10R3, 10R4, 10R6, 105R

No.	Description	Material
1	Plate	PEEK/PFA
2	Diaphragm assembly	EPDM/FKM/Kalrez®
3	Body	PBT
4	Slide bushing assembly	POM/Stainless steel
5	Armature assembly	Stainless steel/PBT
6	Coil assembly	—
7	Sleeve	SUY
8	Spacer	PBT
9	Return spring	Stainless steel
10	Board assembly	—
11	Casing	PBT
12	Plug	NBR
13	O-ring	NBR
14	O-ring	EPDM/FKM/Kalrez®

**Compact Direct Operated
2/3 Port Solenoid Valve for Chemicals Series LVM10/100**

Dimensions: Body Ported

LVM11-□□-□ (N.C.)

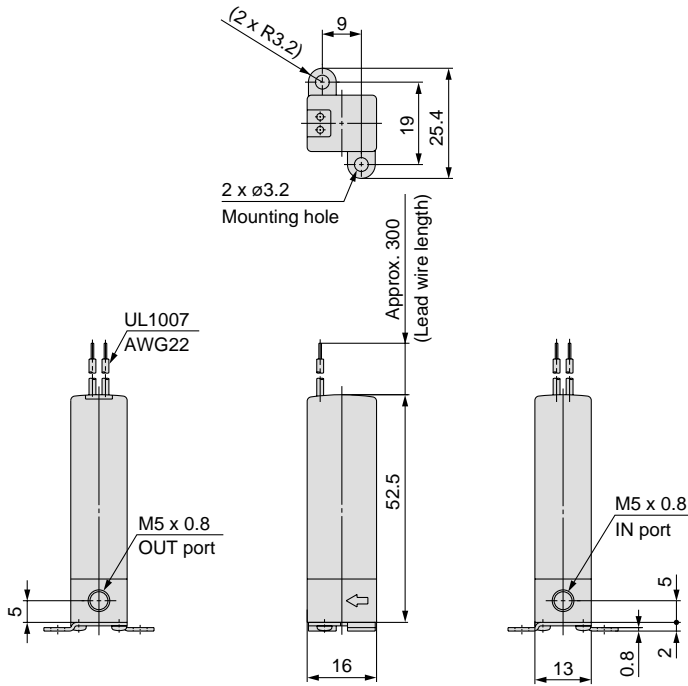

LVM10R1-□□-□ (N.C.)

LVM10R2-□□-□ (N.O.)

LVM102R-□□-□ (Universal)

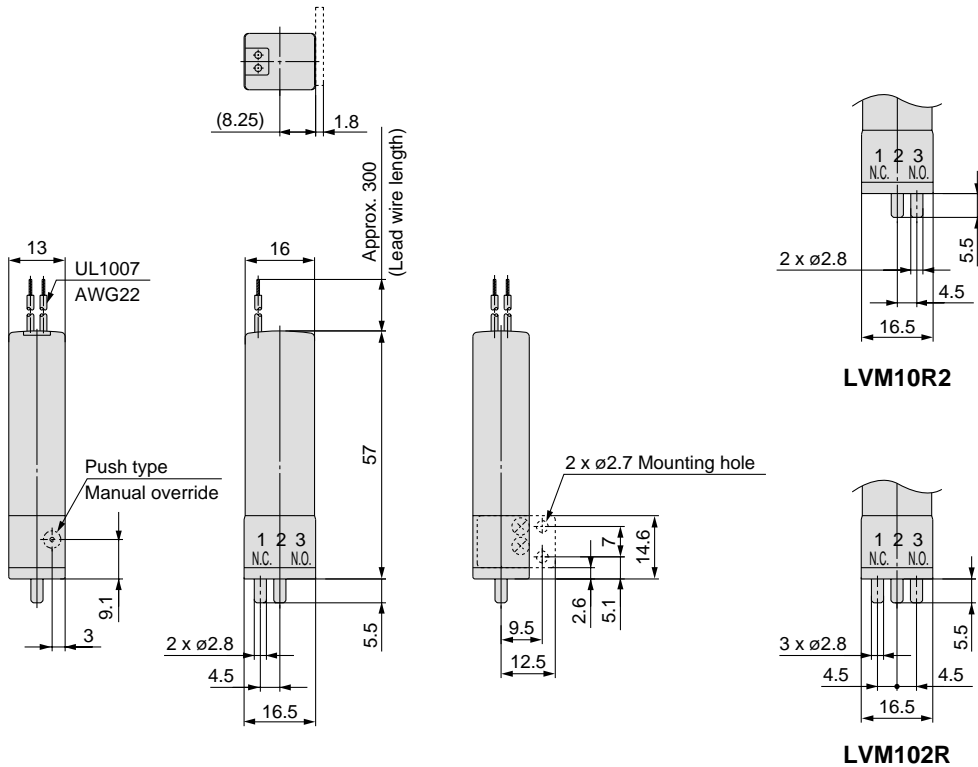

* The broken lines indicate with bracket.

VX2

VXD

VXZ

VXE

VXP

VXR

VXH

VXF

VX3

VXA

VCH□

VDW

VQ

LVM

VCA

VCB

VCL

VCS

VCW

Series LVM10/100

Dimensions: Base Mounted

LVM10R3-□□-□ (N.C.)

LVM10R4-□□-□ (N.O.)

LVM10R6-□□-□ (N.C.)

LVM105R-□□-□ (Universal)

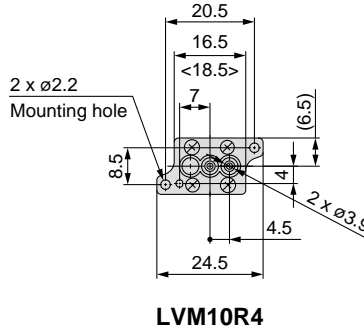
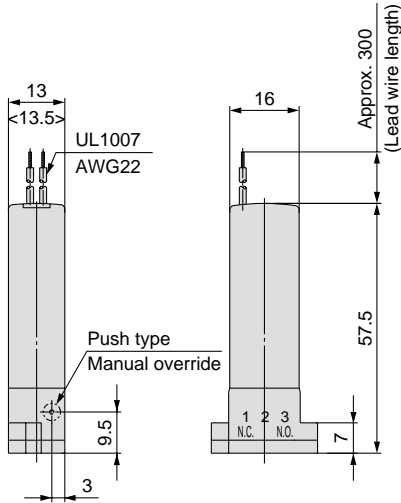

LVM10R4

* The figures in brackets $\langle \rangle$ indicate the values for PFA plate material (wetted part material "E, F, G"). In the case of PFA plate material (wetted part material "E, F, G"), there is no $\phi 1.6$ positioning hole.

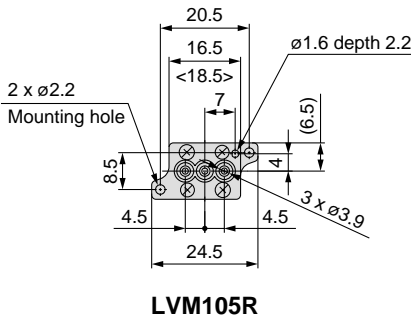

LVM105R

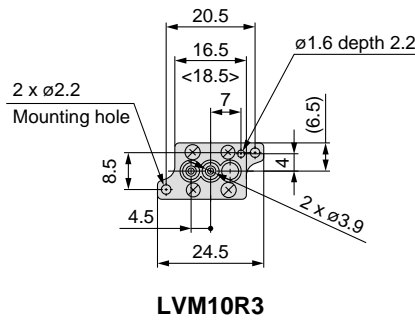

LVM10R3

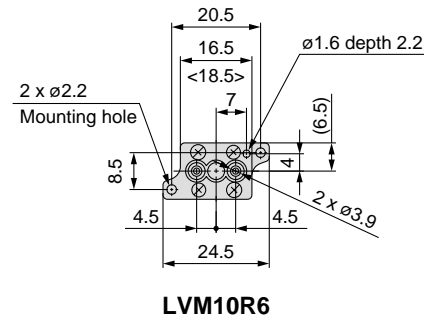

LVM10R6

Recommended interface dimensions

* Surface roughness = Rz3.2 or less

* Surface roughness = Rz3.2 or less

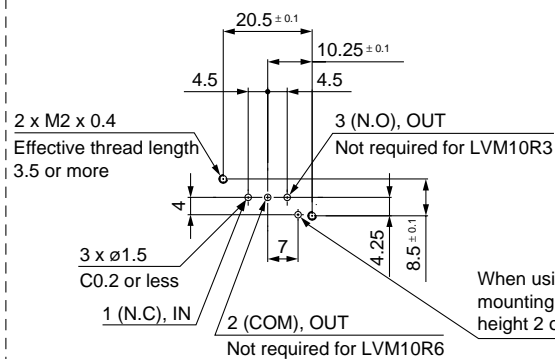

LVM10R3, LVM10R6, LVM105R

When using a positioning pin for mounting, please use $\phi 1.5$ and height 2 or less.

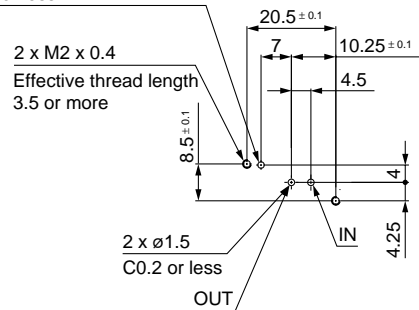

LVM10R4

Compact Direct Operated 2/3 Port Solenoid Valve for Chemicals *Series LVM10/100*

Dimensions: Base Mounted

- LVM10R3-□□□-□ (N.C.)
- LVM10R4-□□□-□ (N.O.)
- LVM10R6-□□□-□ (N.C.)
- LVM105R-□□□-□ (Universal)

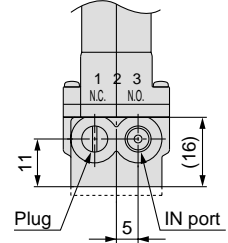
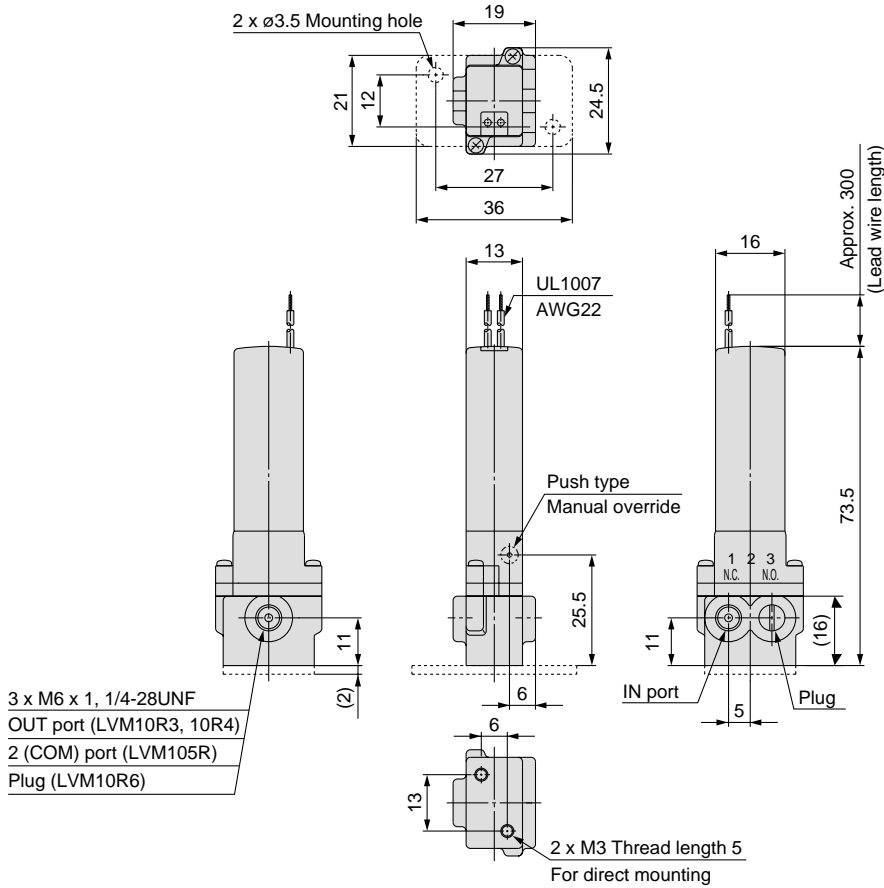

LVM10R4

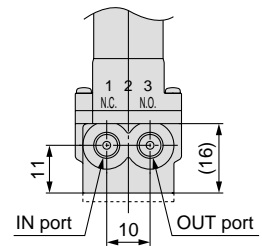

LVM10R6

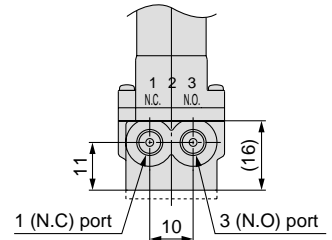

LVM105R

* The broken lines indicate with bracket.

VX2

VXD

VXZ

VXE

VXP

VXR

VXH

VXF

VX3

VXA

VCH□

VDW

VQ

LVM

VCA

VCB

VCL

VCS

VCW

Compact Direct Operated 2/3 Port Solenoid Valve for Chemicals Series **LVM15/150**

How to Order



Base Mounted

LVM 15R3 Y - 5 A - [] - []

Symbol

Symbol	Number of ports	Valve type	
15R3	2	N.C.	
15R4		N.O.	
155R	3	Universal	

• CE compliant

Symbol	None
Q	CE compliant

• Lead wire length

Symbol	300 mm
6	600 mm
10	1000 mm

• Wetted part material

Symbol	Plate	Diaphragm
A	PEEK	EPDM
B	PEEK	FKM
C	PEEK	Kalrez®

• Coil voltage

Symbol	Voltage
5	24 VDC
6	12 VDC

• Function

Symbol	Specifications
Y	Standard (With power-saving circuit)
HY	High-pressure type (With power-saving circuit)

Specifications

Model	Base mounted		
	LVM15R3	LVM15R4	LVM155R
Valve construction	Diaphragm type direct operated poppet (Rocker type)		
Valve type	N.C.	N.O.	Universal
Number of ports	2		3
Fluid ^{Note 1)}	Air, Water, Pure water, Diluent, Cleaning fluid		
Operating pressure range	-75 kPa to 0.25 MPa [0 to 0.6 MPa]		
Orifice diameter	1.6 mm [1 mm]		
Response time	15 ms or less (at pneumatic pressure)		
Leakage	Zero leakage, either external or internal (at water pressure)		
Proof pressure ^{Note 2)}	0.38 MPa [0.9 MPa]		
Ambient temperature	0 to 50°C		
Fluid temperature	0 to 50°C (No condensation)		
Volume of valve chamber ^{Note 3)}	50 μl		
Mounting orientation ^{Note 4)}	Free		
Enclosure	IP40 or equivalent		
Mass	45 g		
Rated voltage	12, 24 VDC		
Allowable voltage fluctuation ^{Note 5)}	±10% of rated voltage		
Type of coil insulation	Class B		
Power consumption (When rated voltage is at 24 V)	Inrush	5.5 W (0.23 A)	
	Holding	1 W	
Coil switching noise ^{Note 6)}	60 dB		

[] indicates high-pressure type.

Note 1) Select an appropriate material for the wetted part when fluid such as a cleaning solvent is used. Also, be sure to confirm the fluid compatibility in advance.

Note 2) Indicates the pressure which does not generate breakage, cracks or external leakage after a one-minute airtight test.

Note 3) Indicates the volume of clearance inside the valve chamber after the volume of the diaphragm is subtracted.

Note 4) Since the body (orifice shape) is designed to eliminate residual liquid, mounting in a vertical direction with the coil at the top is recommended. When residual liquid is not considered, any mounting orientation is available.

Note 5) When the response speed is regarded as important, prevent negative fluctuation of the voltage by adequate regulation.

Note 6) The value is based on SMC's measurement conditions. The noise level will vary with conditions.

Note 7) Refer to 10 in "Design and Selection" on the back of page 302, if the valve is to be energized continuously for extended periods of time.

Flow Characteristics

Water		Air	
Av	Cv	C	b
0.96 x 10 ⁻⁶	0.04	0.13	0.22
[0.36 x 10 ⁻⁶]	[0.015]	[0.05]	[0.2]

[] indicates high-pressure type.

* The values of Av and Cv are based on JIS B 2005:1995, C and b are based on JIB B 8390:2000.

Construction: Base Mounted

LVM15R3

LVM15R4

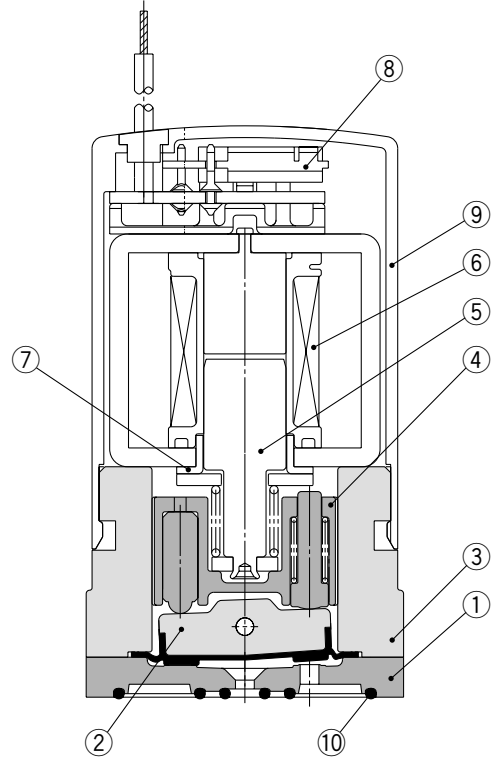
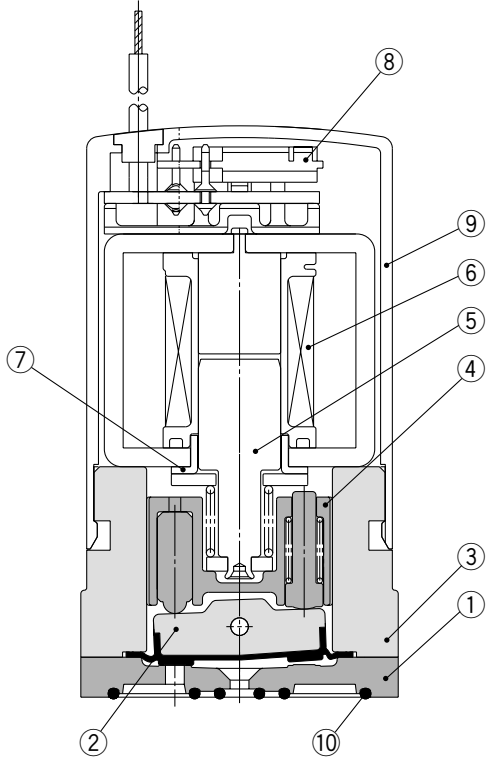

LVM155R

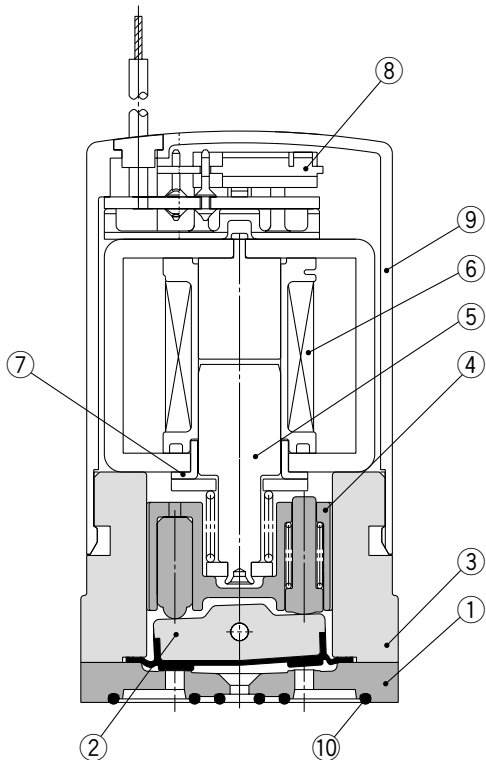

- VX2
- VXD
- VXZ
- VXE
- VXP
- VXR
- VXH
- VXF
- VX3
- VXA
- VCH□
- VDW
- VQ
- LVM**
- VCA
- VCB
- VCL
- VCS
- VCW

Component Parts: LVM15R3, 15R4, 155R

No.	Description	Material
1	Plate	PEEK
2	Diaphragm assembly	EPDM/FKM/Kalrez®
3	Body	PBT
4	Slide bushing assembly	PPS/Stainless steel
5	Armature assembly	—
6	Coil assembly	—
7	Sleeve	SUY
8	Board assembly	—
9	Casing	PBT
10	Interface gasket	EPDM/FKM/Kalrez®

Series LVM15/150

Dimensions: Base Mounted

LVM15R3
LVM15R4
LVM155R

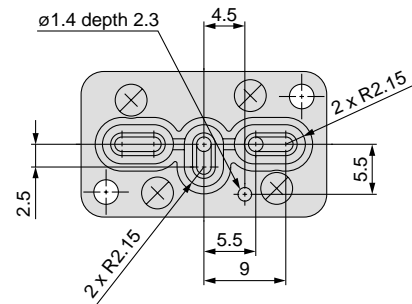
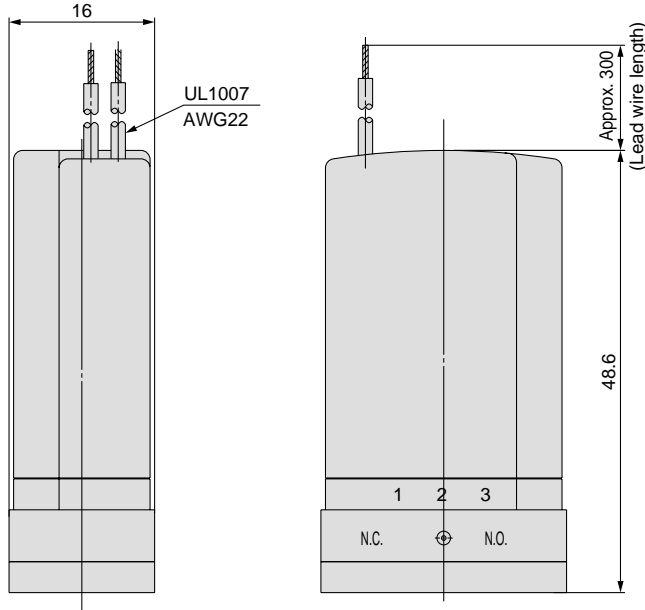
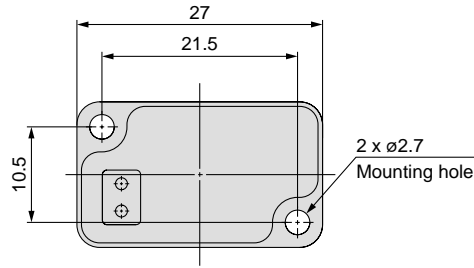

LVM15R4

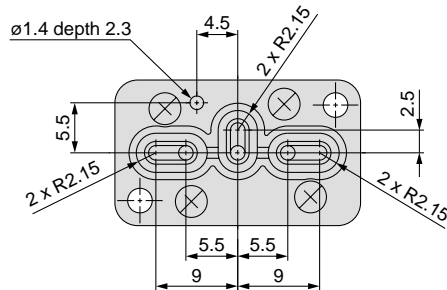

LVM155R

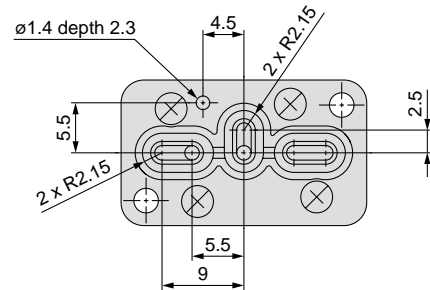

LVM15R3

Recommended interface dimensions

* Surface roughness = Rz3.2 or less

* Surface roughness = Rz3.2 or less

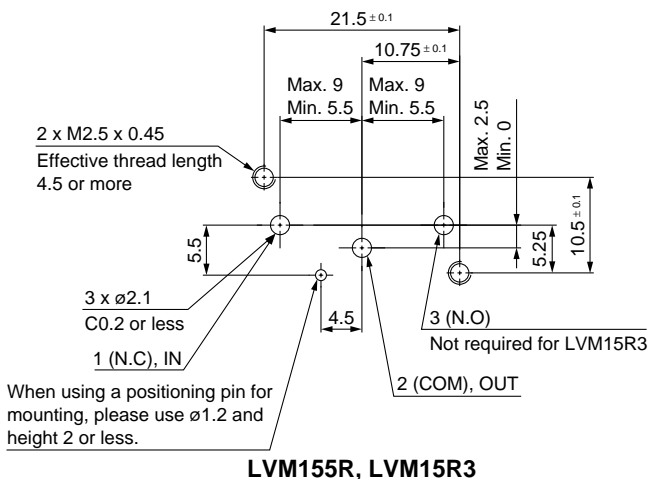

LVM155R, LVM15R3

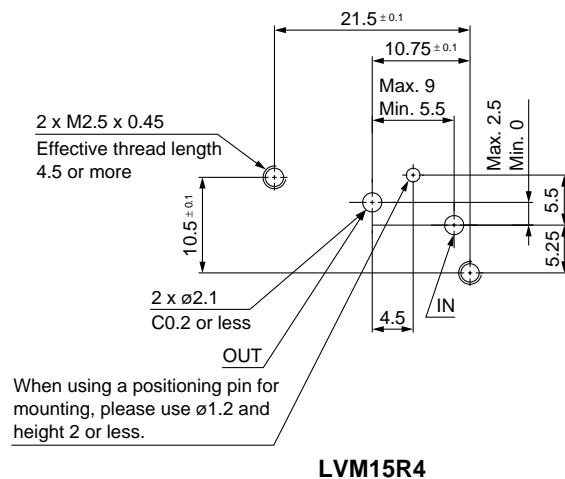

LVM15R4

Compact Direct Operated 2/3 Port Solenoid Valve for Chemicals Series *LVM20/200*

How to Order

Base Mounted

LVM 20R3 - **5** **A** - -

Symbol	Number of ports	Valve type	
20R3	2	N.C.	
		N.O.	
20R4	2	N.O.	
205R	3	Universal	

CE compliant	
Nil	None
Q	CE compliant

Lead wire length	
Nil	300 mm
6	600 mm
10	1000 mm

Wetted part material		
Symbol	Plate	Diaphragm
A	PEEK	EPDM
B	PEEK	FKM
C	PEEK	Kalrez®

Coil voltage	
Symbol	Voltage
5	24 VDC
6	12 VDC

Function	
Nil	Standard
Y	With power-saving circuit



VX2

VXD

VXZ

VXE

VXP

VXR

VXH

VXF

VX3

VXA

VCH□

VDW

VQ

LVM

VCA

VCB

VCL

VCS

VCW

Specifications

Model	Base mounted		
	LVM20R3	LVM20R4	LVM205R
Valve construction	Diaphragm type direct operated poppet (Rocker type)		
Valve type	N.C.	N.O.	Universal
Number of ports	2		3
Fluid ^{Note 1)}	Air, Water, Pure water, Diluent, Cleaning fluid		
Operating pressure range	-75 kPa to 0.3 MPa		
Orifice diameter	2 mm		
Response time	20 ms or less (at pneumatic pressure)		
Leakage	Zero leakage, either external or internal (at water pressure)		
Proof pressure ^{Note 2)}	0.45 MPa		
Ambient temperature	0 to 50°C		
Fluid temperature	0 to 50°C (No condensation)		
Volume of valve chamber ^{Note 3)}	84 μl		
Mounting orientation ^{Note 4)}	Free		
Enclosure	IP40 or equivalent		
Mass	80 g		
Rated voltage	12, 24 VDC		
Allowable voltage fluctuation ^{Note 5)}	±10% of rated voltage		
Type of coil insulation	Class B		
Power consumption (When rated voltage is at 24 V)	Standard		2.5 W (0.1 A)
	With power-saving circuit	Inrush	4 W (0.17 A)
		Holding	0.6 W
Coil switching noise ^{Note 6)}	60 dB		

Note 1) Select an appropriate material for the wetted part when fluid such as a cleaning solvent is used. Also, be sure to confirm the fluid compatibility in advance.

Note 2) Indicates the pressure which does not generate breakage, cracks or external leakage after a one-minute airtight test.

Note 3) Indicates the volume of clearance inside the valve chamber after the volume of the diaphragm is subtracted.

Note 4) Since the body (orifice shape) is designed to eliminate residual liquid, mounting in a vertical direction with the coil at the top is recommended. When residual liquid is not considered, any mounting orientation is available.

Note 5) When the response speed is regarded as important, prevent negative fluctuation of the voltage by adequate regulation.

Note 6) The value is based on SMC's measurement conditions. The noise level will vary with conditions.

Note 7) Refer to 10 in "Design and Selection" on the back of page 302, if the valve is to be energized continuously for extended periods of time.

Flow Characteristics

Water		Air	
Av	Cv	C	b
1.56 x 10 ⁻⁶	0.065	0.23	0.27

* The values of Av and Cv are based on JIS B 2005:1995, C and b are based on JIB B 8390:2000.

Series LVM20/200

Construction: Base Mounted

LVM20R3

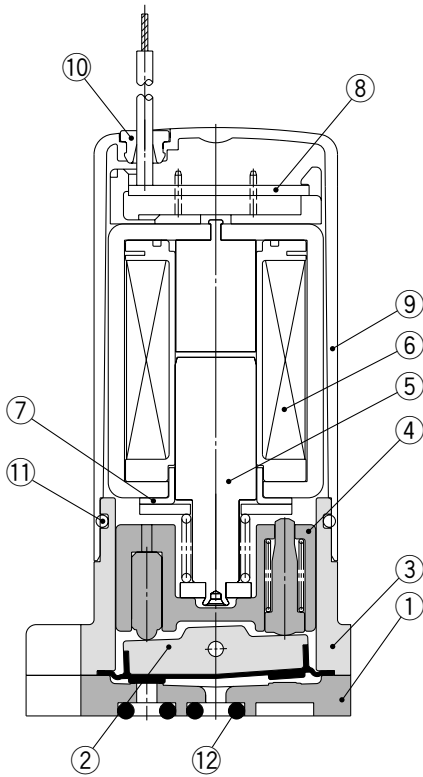

LVM20R4

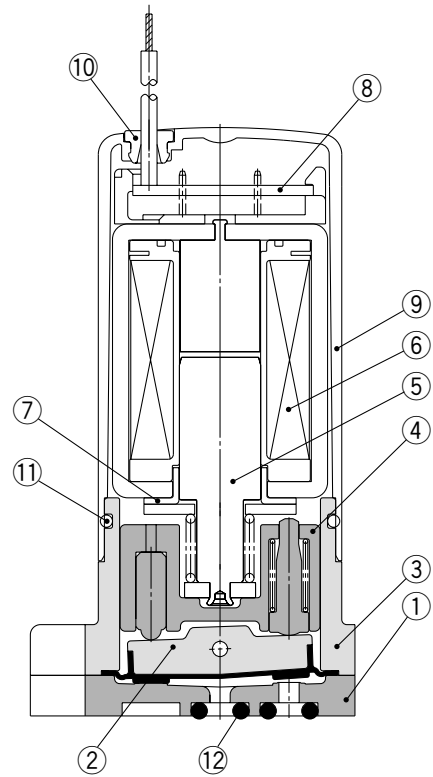

LVM205R

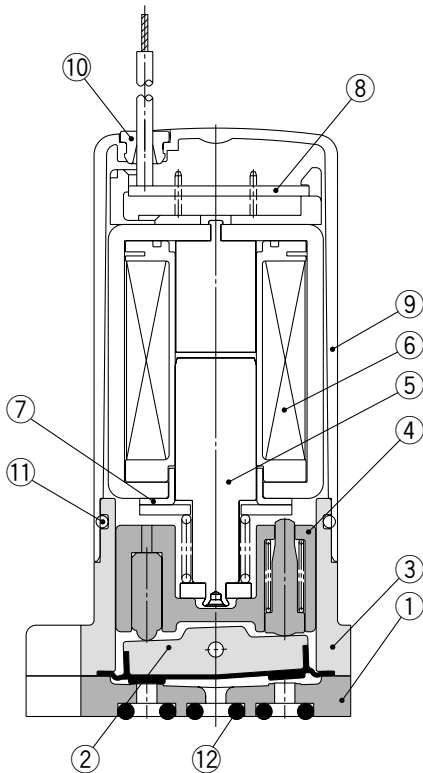

Component Parts: LVM20R3, 20R4, 205R

No.	Description	Material
1	Plate	PEEK
2	Diaphragm assembly	EPDM/FKM/Kalrez®
3	Body	PBT
4	Slide bushing assembly	PPS/Stainless steel
5	Armature assembly	—
6	Coil assembly	—
7	Sleeve	SUY
8	Board assembly	—
9	Casing	PBT
10	Plug	NBR
11	O-ring	NBR
12	O-ring	EPDM/FKM/Kalrez®

Compact Direct Operated 2/3 Port Solenoid Valve for Chemicals *Series LVM20/200*

Dimensions: Base Mounted

LVM20R3
LVM20R4
LVM205R

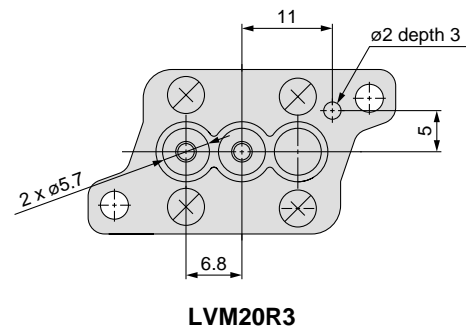
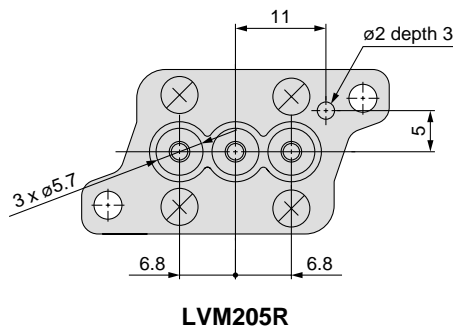
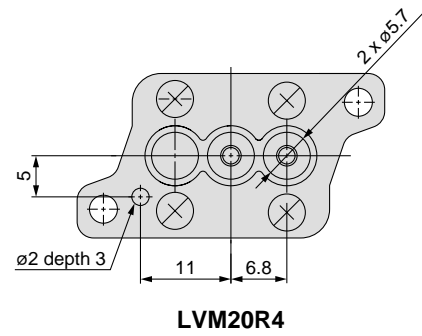
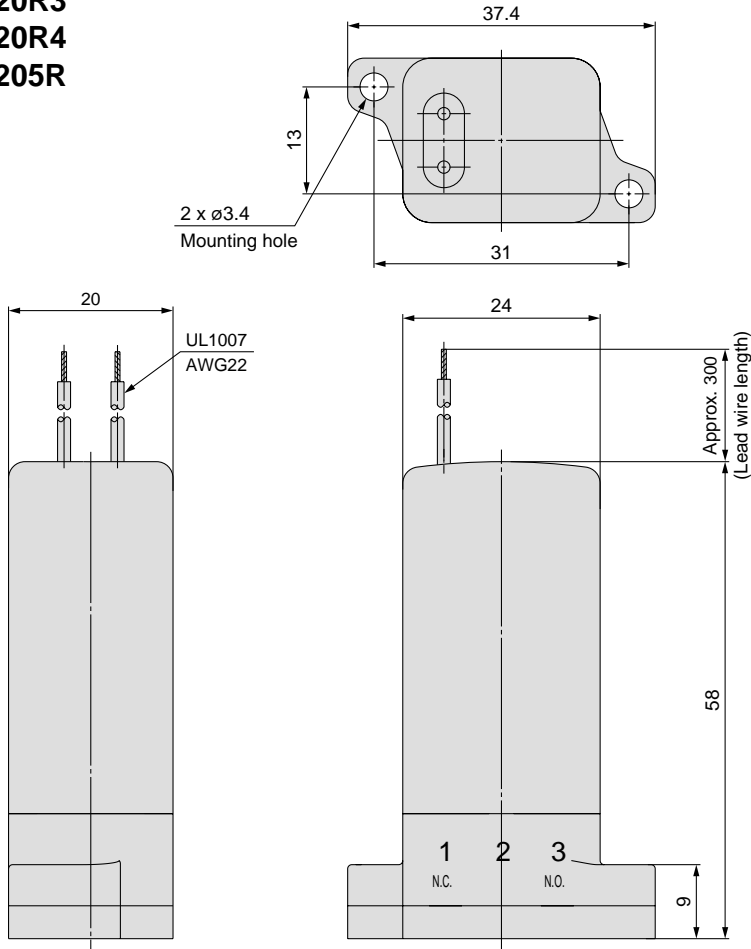

Recommended interface dimensions

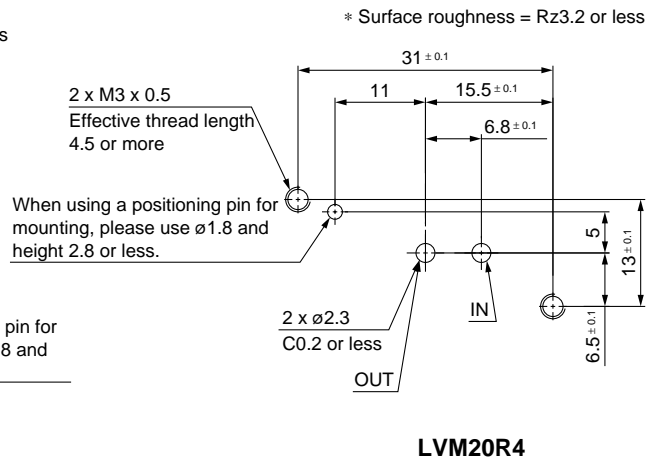
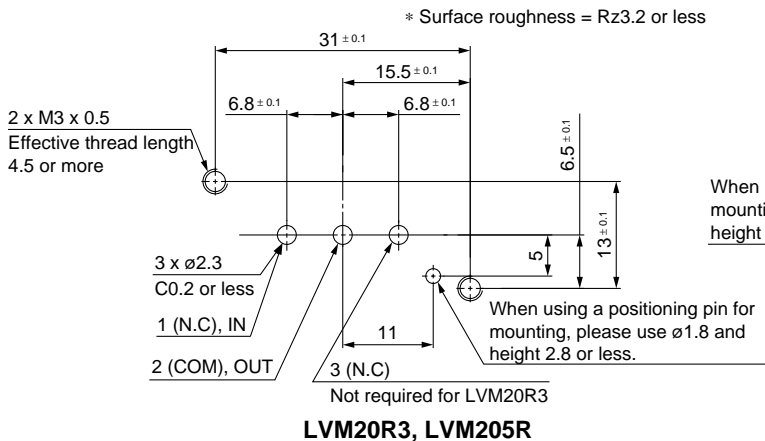

VX2

VXD

VXZ

VXE

VXP

VXR

VXH

VXF

VX3

VXA

VCH □

VDW

VQ

LVM

VCA

VCB

VCL

VCS

VCW



Series LVM Specific Product Precautions 1

Be sure to read this before handling. Contact SMC when it is used in conditions other than the specifications.

Design and Selection

Warning

- Do not use this product in applications which may adversely affect human life (e.g. medical equipment connected to the human body for drip infusion).**
- Confirm the specifications.**
Give careful consideration to the operating conditions such as the application, fluid and environment, and use within the operating ranges specified in this catalog.
- Fluid**
Be sure to confirm the compatibility between the component material and the fluid.
- Maintenance space**
The installation should allow sufficient space for maintenance activities.
- Fluid pressure range**
Fluid pressure should be within the allowable pressure range.
- Ambient environment**
Use within the allowable ambient temperature range. Be sure that the fluid used does not touch the external surface of the product.
- Countermeasures against static electricity**
Take measures to prevent static electricity since some fluids can cause static electricity.
- Pressure (including vacuum) holding**
It is not usable for an application such as holding the pressure (including vacuum) inside of a pressure vessel because air leakage is entailed in a valve.
- Cannot be used as an emergency shutoff valve, etc.**
The valves presented in this catalog are not designed for safety applications such as an emergency shutoff valve. If the valves are used in this type of system, other reliable safety assurance measures should also be adopted.
- Extended periods of continuous energization**

Power-saving circuit waveform (example)

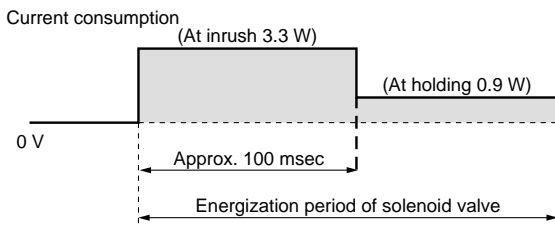

- * Power consumption for the waveform shown above is that of the LVM09/090.
- * For the LVM15/150, the type with power-saving circuit is standard.
- * For the LVM10/100, the inrush is 50 msec.

When a solenoid valve without a power-saving circuit is continuously energized for long periods of time, temperature increase from coil heat release can result in worsening performance and shortened service life of the solenoid valve, as well as adverse effects on peripheral equipment in the vicinity. For this reason, when valves are to be continuously energized for extended periods, use a fan or take other measures to disperse heat and keep valve surface temperatures at 70°C or less.

The table below shows reference values for continuously energized valves (single unit) when surface temperature is 70°C or less.

Series	LVM09/090	LVM10/100	LVM20/200
Period of continuous energization	5 min. or less	30 min. or less	30 min. or less
Duty ratio	50% or less		
Ambient temperature	25°C or less		
Power-saving circuit	None		

* Duty ratio: ON time/(ON time + OFF time)

* For the LVM15/150, the type with power-saving circuit is standard.

Please use a fan or take other measures to disperse heat and keep temperatures within the specified range when mounting the solenoid valves inside control panels, etc. Be especially careful when using three or more adjacent valves with manifolds and keeping them continuously energized for extended period, as this may result in dramatic increases in temperature.

- Please use valve pitches equal to or above those shown in the table below when using multiple valves together.**

Series	LVM09/090	LVM10/100	LVM15/150	LVM20/200
Valve pitch	10.5	14	17	21

Selection

Caution

Leakage voltage

Particularly when using a resistor in parallel with a switching element and using a C-R element (surge voltage suppressor) to protect the switching element, take note that leakage current will flow through the resistor, C-R element, etc., creating a possible danger that the valve may not turn off.

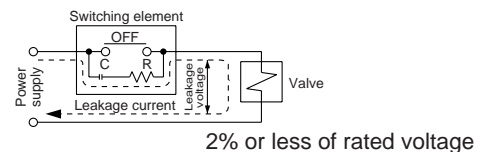

Mounting

Warning

- If air leakage increases or equipment does not operate properly, stop operation.**
After mounting is completed, confirm that it has been done correctly by performing a suitable function test.
- Since the body (orifice shape) is designed to eliminate residual liquid, mounting in a vertical direction with the coil at the top is recommended.**

When residual liquid is not considered, any mounting position is possible.



Series LVM Specific Product Precautions 2

Be sure to read this before handling. Contact SMC when it is used in conditions other than the specifications.

Piping

⚠ Caution

1. Preparation before piping

Before piping is connected, it should be thoroughly blown out with air (flushing) or washed to remove chips, cutting oil and other debris from inside the pipe.

2. When tubing is directly connected to the solenoid valve, insert the tubing straight into the nipple for a complete fit.

The reference inner diameter of the tubing is $\phi 2.5$ or less. Exercise care in selecting the tubing so that the outer diameter of the tubing after being connected does not exceed $\phi 4.5$.

The holding force varies by the tubing material. Be sure to confirm the holding force of each material before operation.

After connecting the tubing, care should be taken not to put excessive force (tensile force, compression, bending, etc.) on the tubing. Applying an external force of greater than 20 N to the nipple may cause leakage.

Models: LVM10R1, 10R2, 102R

3. Always tighten threads with the proper tightening torque.

Screw the fitting into the solenoid valve and tighten by referring to the tightening torque below.

Models: LVM11, 10R3, 10R4, 10R6, 105R

Tightening Torque for Piping

Model	Thread size	Proper tightening torque N·m	
Base mounted LVM09R3, 09R4, 095R	M2	0.1 to 0.14	
Body ported LVM11	M5	1.5 to 2	
Base mounted LVM10R3, 10R4, 10R6, 105R	Without sub-plate	M2 (Note)	0.15 to 0.2
	With sub-plate	M6 or 1/4-28UNF	1.5 to 2
Base mounted LVM15R3, 15R4, 155R	M2.5	0.25 to 0.35	
Base mounted LVM20R3, 20R4, 205R	M3	0.4 to 0.6	

Note) At base mounted

* Reference

M5, M6, 1/4-28UNF thread type fitting: After tightening by hand, tighten approximately 1/6 turn with a tightening tool.

Wiring

⚠ Caution

1. Use electrical circuits which do not generate chattering in their contacts.

2. Use voltage which is within $\pm 10\%$ of the rated voltage.

However, when the response time is important, control the voltage to avoid variation on the minus side.

3. Apply the correct voltage.

Applying incorrect voltage may cause a malfunction or a burned coil.

4. Connect the wires so that an external force of greater than 10 N is not applied to the lead wire.

Otherwise the coil will burn.

5. Units with power-saving circuits use polarized electrical connections.

Red (+), Black (-)

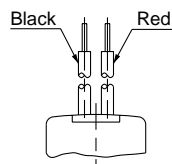

Fluid Properties

⚠ Warning

Liquid (chemicals)

Component crystallizes or clots depending on its nature. Leakage will occur when a crystallized or clotted component is caught between the sealing parts.

Take measures to clean such component if necessary.

Water

Install a filter strainer of about 100 mesh on the inlet side of the piping.

Air

Compressed air filtered with a filter with filtration rating of 5 μm or less, which is mounted on the inlet side of the piping, should be used.

Operating Environment

⚠ Warning

1. Do not use in explosive atmospheres.

2. Do not use in locations subject to excessive vibration or impact.

Impact resistance of this solenoid valve is 150 m/s². Vibration resistance of this solenoid valve is 30 m/s².

3. Do not use in locations where radiated heat will be received from nearby heat sources.

Maintenance

⚠ Warning

1. Removing the product

Shut off the fluid supply and release the fluid pressure in the system. Shut off the power supply. Remove the product.

2. Before operating, remove residual chemicals and completely replace it with deionized water, air, etc.

3. Do not disassemble the product.

Products which have been disassembled cannot be guaranteed. If disassembly is necessary, contact SMC.

VX2

VXD

VXZ

VXE

VXP

VXR

VXH

VXF

VX3

VXA

VCH□

VDW

VQ

LVM

VCA

VCB

VCL

VCS

VCW