



Industrial Ball Valves

Index

Safety Warning	Inside Front Cover
7510 Series 2-Piece Ball Valve	1
7520 Series 3-Piece Ball Valve	3
7520 Series 3-Piece Ball Valve with GYROLOK® Tube End Fittings	5
Thread Specification High Tolerance	7
Disclaimers	Inside Back Cover



(Optional Oval Handle-Uninstalled)

industrial ball valves

Family Features

- Low Pressure Design for Non-Critical Service
- Includes High Tolerance NPT Thread or Unique GYROLOK® Tube Connections
- Stainless Steel Construction
- Locking Handles



CRANE Instrumentation & Sampling, HOKE®
PO Box 4866 • Spartanburg, SC 29305-4866
(864) 574-7966 • www.hoke.com

For Your Safety

It is solely the responsibility of the system designer and user to select products suitable for their specific application requirements and to ensure proper installation, operation, and maintenance of these products. When selecting products, the total system design must be considered to ensure safe, trouble-free performance. Material compatibility, product ratings and application details should be considered in the selection. Improper selection or use of products described herein can cause personal injury or property damage.

Contact your authorized HOKE® sales and service representative for information about additional sizes and special alloys.

SAFETY WARNING:

HOKE® products are designed for installation only by professional suitably qualified licensed system installers experienced in the applications and environments for which the products are intended. These products are intended for integration into a system. Where these products are to be used with flammable or hazardous media, precautions must be taken by the system designer and installer to ensure the safety of persons and property. Flammable or hazardous media pose risks associated with fire or explosion, as well as burning, poisoning or other injury or death to persons and/or destruction of property. The system designer and installer must provide for the capture and control of such substances from any vents in the product(s). The system installer must not permit any leakage or uncontrolled escape of hazardous or flammable substances. The system operator must be trained to follow appropriate precautions and must inspect and maintain the system and its components including the product(s) and at regular intervals in accordance with timescales recommended by the supplier to prevent unacceptable wear or failure.

2-Piece Standard Port Ball Valves

Threaded Ends, 2000 PSI (138 Bar) W.O.G.

Features

- Reinforced TFE seats increase durability
- Adjustable packing gland
- Bottom-loaded blow-out proof stem
- Basic design complies with ANSI B16.34 & EN 12516-1
- High Tolerance NPT Thread Specification
- Tested according to API 598
- Lever Style handle with locking device
- Part Number and Brand embossed on the body
- Tapped Mounting Pad

Family Features

- Low Pressure Design for Non-Critical Service
- Includes High Tolerance NPT Thread or Unique GYROLOK® Tube Connections
- Stainless Steel Construction
- Locking Handles

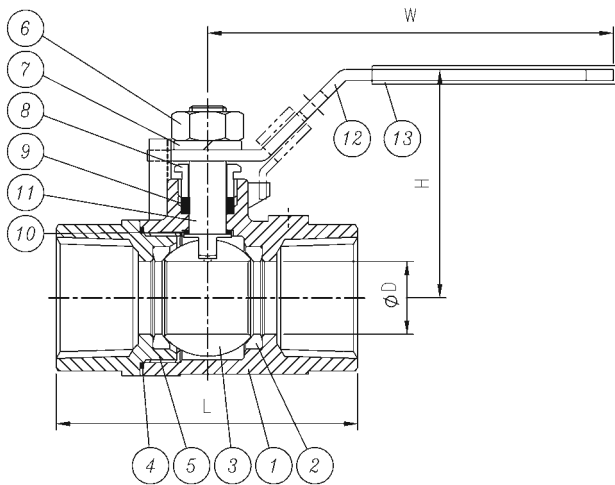
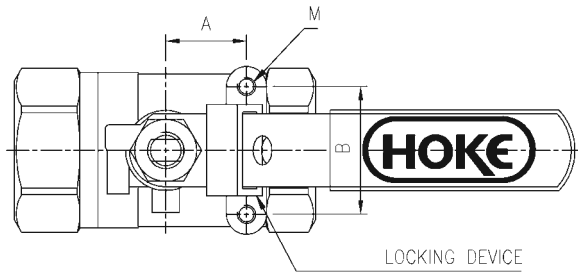

Materials List

PARTS S-	7510F (X)Y
1	Body ASTM A351-CF8M/316
2	Seat Reinforced PTFE
3	Ball ASTM A351-CF8M/316
4	Gasket PTFE
5	End Cap ASTM A351-CF8M/316
6	Handle Nut AISI 304
7	Handle Washer AISI 304
8	Gland AISI 304
9	Stem Packing PTFE
10	Thrust Washer PTFE
11	Stem ASTM A276-316
12	Handle AISI 304
13	Handle Cover PVC

How To Order:

PART #	SIZE	ØD	L	A	B	H	W	M
7510F4Y	inch - ¼"	0.37	2.09	0.50	1.12	2.13	3.80	10-24UNC
7510F6Y	inch - ⅜"	0.37	2.09	0.50	1.12	2.13	3.80	10-24UNC
7510F8Y	inch - ½"	0.49	2.38	0.50	1.12	2.13	3.80	10-24UNC
7510F12Y	inch - ¾"	0.59	2.70	0.50	1.12	2.24	3.80	10-24UNC
7510F16Y	inch - 1"	0.79	3.25	0.87	1.38	2.46	4.47	10-24UNC
7510F20Y	inch - 1¼"	0.98	3.58	0.93	1.38	2.87	5.47	10-24UNC
7510F24Y	inch - 1½"	1.26	3.94	0.93	1.50	3.09	5.47	¼-20UNC
7510F32Y	inch - 2"	1.50	4.61	0.93	1.50	3.48	6.67	¼-20UNC

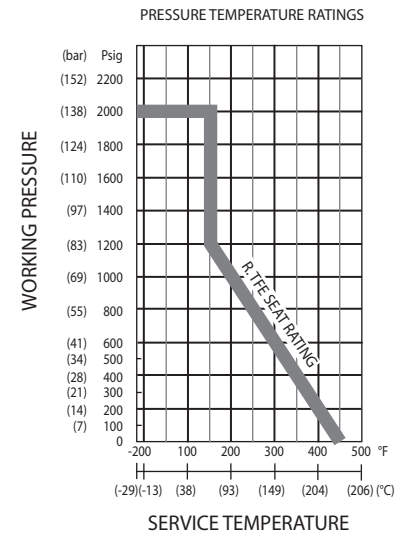

3-Piece Full Port Ball Valves

Threaded Ends, 1/4"-1/2": 3000PSI (207 Bar) W.O.G.,
 3/4"-1": 2000PSI (138 Bar) W.O.G. Enclosed Bolt
 Type, ISO 5211 Direct Actuator Mounting Pad

Features

- Strengthened construction fully complied with ASME/ANSI B16.34 secures 3000 psi/2000 psi working pressure rating.
- Fully encapsulated bolts are protected from the environment for extended service life.
- Live-loaded packing gland design for self-adjustment of packing compression.
- Equalized cavity pressure hole drilled in the stem slot of ball.
- Bottom-loaded blow-out proof stem.
- Pressure equalizing seats
- Basic design complies with ANSI B16.34.
- Tested according to API 598
- High tolerance NPT Thread Specification
- Part number and brand embossed on body
- **Optional oval handle available (uninstalled)**

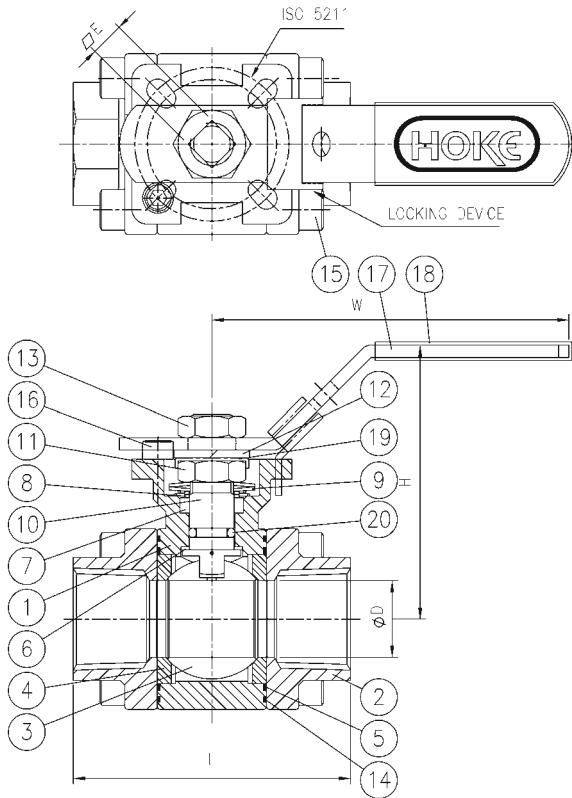

Materials List

PARTS -	7520F (XY)
1	Body ASTM A351-CF8M/316
2	End Cap ASTM A351-CF8M/316
3	Ball ASTM A351-CF8M/316
4	Seat TFM4215
5	Gasket PTFE
6	Thrust Washer PTFE
7	Stem Packing Graphite
8	Gland AISI 304
9	Belleville Washer AISI 301
10	Stem ASTM A276-316
11	Packing Nut AISI 304
12	Spring Washer AISI 304
13	Handle Nut AISI 304
14	Gasket Graphite
15	Bolt AISI 304
16	Stop Screw AISI 304
17	Handle AISI 304
18	Handle Cover PVC
19	Nut Lock AISI 304
20	O-Ring Viton

How To Order

PART #	SIZE	ØD	L	E	H	W	ISO 5211	OPTIONAL OVAL HANDLE
7520F4Y	inch - 1/4"	0.43	2.62	0.35	2.68	5.41	F03-F04	7520F4Y-OH
7520F6Y	inch - 3/8"	0.49	2.62	0.35	2.68	5.41	F03-F04	7520F6Y-OH
7520F8Y	inch - 1/2"	0.59	2.76	0.35	2.68	5.41	F03-F04	7520F8Y-OH
7520F12Y	inch - 3/4"	0.59	3.15	0.35	2.78	5.41	F03-F04	7520F12Y-OH
7520F16Y	inch - 1"	1.00	3.54	0.43	3.50	6.60	F04-F05	7520F16Y-OH

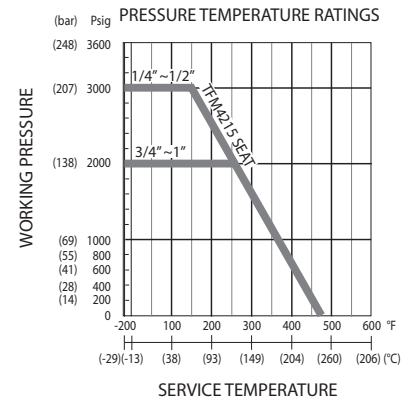

3-Piece Full Port Ball Valves

GYROLOK® End Tube Fittings, 1/4" - 1/2": 3000PSI (207 Bar)
 W.O.G., 3/4"-1": 2000PSI (138 Bar) W.O.G.
 Enclosed Bolt Type, ISO 5211 Direct
 Actuator Mounting Pad



Features

- Strengthened construction fully complied with ASME/ANSI B16.34 secures 3000 psi/2000 psi working pressure rating.
- Fully encapsulated bolts are protected from the environment for extended service life.
- Live-loaded packing gland design for self-adjustment of packing compression.
- Equalized cavity pressure hole drilled in the stem slot of ball.
- Bottom-loaded blow-out proof stem.
- Pressure equalizing seats
- Basic design complies with ANSI B16.34.
- Tested according to API 598
- GYROLOK® Tube Fitting End Connections
- Part number and brand embossed on body
- **Optional oval handle available (uninstalled)**

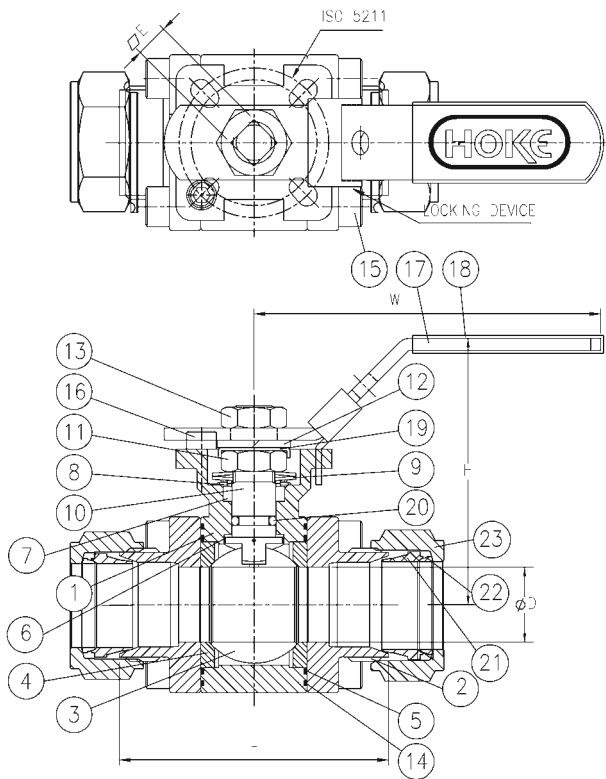

Materials List

PARTS S-	7520G (XY)
1	Body ASTM A351-CF8M/316
2	End Cap ASTM A351-CF8M/316
3	Ball ASTM A351-CF8M/316
4	Seat TFM4215
5	Gasket PTFE
6	Thrust Washer PTFE
7	Stem Packing Graphite
8	Gland AISI 304
9	Belleville Washer AISI 301
10	Stem ASTM A276-316
11	Packing Nut AISI 304
12	Spring Washer AISI 304
13	Handle Nut AISI 304
14	Gasket Graphite
15	Bolt AISI 304
16	Stop Screw AISI 304
17	Handle AISI 304
18	Handle Cover PVC
19	Nut Lock AISI 304
20	O-Ring Viton

How To Order

PART #	SIZE	ØD	L	E	H	W	ISO 5211	OPTIONAL OVAL HANDLE
7520G4Y	inch - 1/4"	0.43	2.62	0.35	2.68	5.41	F03-F04	7520G4Y-OH
7520G6Y	inch - 3/8"	0.49	2.62	0.35	2.68	5.41	F03-F04	7520G6Y-OH
7520G8Y	inch - 1/2"	0.59	2.76	0.35	2.68	5.41	F03-F04	7520G8Y-OH
7520G12Y	inch - 3/4"	0.59	3.15	0.35	2.78	5.41	F03-F04	7520G12Y-OH
7520G16Y	inch - 1"	1.00	3.54	0.43	3.50	6.60	F04-F05	7520G16Y-OH

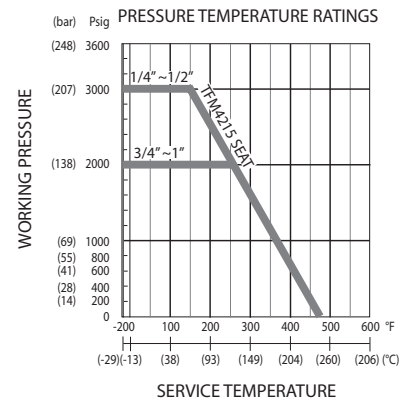

NPT High Tolerance Thread Specification

NPT Engagement using High Tolerance HOKE® NPT Connections has 5-6 threads engaged when fully tightened.



**HOKE® High Tolerance
NPT Thread**

NPT Engagement using ANSI/ ASME B1.20.1 Pipe Thread Standard has only 3-4 threads engaged when fully tightened.



**Standard B1.20.1
NPT Thread**

Tube Fittings

In the early 1960's, HOKE® took the industry by storm, introducing the GYROLOK® tube fitting. To this day, the design features offer unique advantages and benefits to users that are unmatched in the industry.

Key GYROLOK® Design Benefits:

1) Controlled Ferrule Drive and Sizing Angle

- Avoids risks associated with over-tightening and allows for multiple remakes

2) Butt Seal

- Provides an extra level of protection against leaks

3) Special high tolerance NPT thread specification

- Ensures maximum thread engagement for a safer, more robust connection.

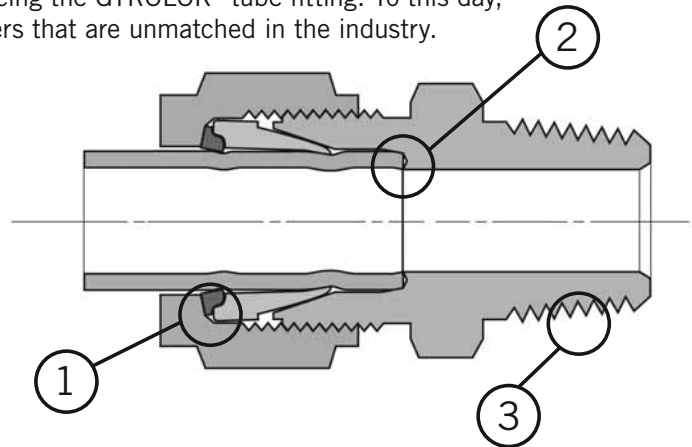

Custom Options

Please consult factory for other materials, bore sizes, handle options and connection options.

The actual pressure ratings for any alternative option will vary from those stated – please consult with factory for your specific requirements.

The specification of any alternative material, connection or tubing is critical to the overall performance of the system.

Caution should be exercised by the user to ensure proper selection in accordance with actual operating or design conditions.

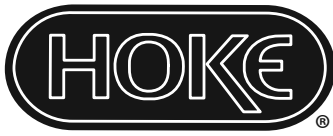

The Small Bore Instrumentation Specialists



We specialize in small bore instrumentation products up to 2" that deliver benchmark performance quality & safety; provide the broadest array of superior alloy offerings in the market; decades of proven success in a wide range of industries; a roster of "who's who" customers & projects globally; original "Best Solution" engineering & designs; and are focused on continuous improvement in all aspects of our business.

Proudly Distributed By:



CRANE INSTRUMENTATION &
SAMPLING Inc.
405 Centura Ct.
Spartanburg, SC 29305, USA
Tel: 1-864-574-7966
PO Box 4866, Spartanburg, SC
29305-4866 USA

Crane Co., and its subsidiaries cannot accept responsibility for possible errors in catalogues, brochures, other printed materials, and website information. Crane Co. reserves the right to alter its products without notice, including products already on order provided that such alteration can be made without changes being necessary in specifications already agreed. All trademarks in this material are the property of the Crane Co. or its subsidiaries. The Crane and Crane brands logotype (CENTER LINE®, COMPAC-NOZ®, CRANE®, DEPA® & ELRO®, DOPAK®, DUO-CHEK®, FLOWSEAL®, GYROLOK®, GO REGULATOR®, HOKE®, JENKINS®, KROMBACH®, NOZ-CHEK®, PACIFIC VALVES®, RESISTOFLEX®, REVO®, SAUNDERS®, STOCKHAM®, TEXAS SAMPLING®, TRIANGLE®, UNI-CHEK®, VALVES®, WTA®, and XOMOX®) are registered trademarks of Crane Co. All rights reserved.