

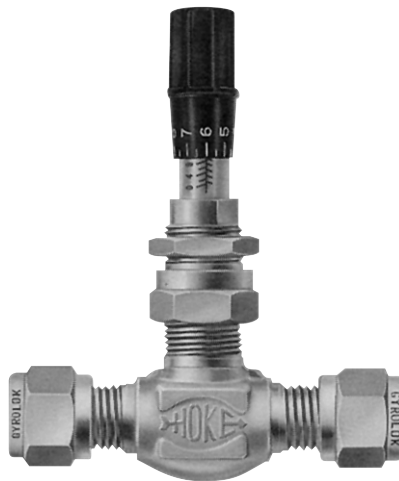

Metering Valves

Index

Safety Warning	Inside Front Cover
1300 Series	1
1600 Series	4
2300 Series	8
Disclaimers	Inside Back Cover



metering valves



CRANE Instrumentation & Sampling, HOKE®
PO Box 4866 • Spartanburg, SC 29305-4866
(864) 574-7966 • www.hoke.com

For Your Safety

It is solely the responsibility of the system designer and user to select products suitable for their specific application requirements and to ensure proper installation, operation, and maintenance of these products. When selecting products, the total system design must be considered to ensure safe, trouble-free performance. Material compatibility, product ratings and application details should be considered in the selection. Improper selection or use of products described herein can cause personal injury or property damage.

Contact your authorized HOKE® sales and service representative for information about additional sizes and special alloys.

SAFETY WARNING:

HOKE® products are designed for installation only by professional suitably qualified licensed system installers experienced in the applications and environments for which the products are intended. These products are intended for integration into a system. Where these products are to be used with flammable or hazardous media, precautions must be taken by the system designer and installer to ensure the safety of persons and property. Flammable or hazardous media pose risks associated with fire or explosion, as well as burning, poisoning or other injury or death to persons and/or destruction of property. The system designer and installer must provide for the capture and control of such substances from any vents in the product(s). The system installer must not permit any leakage or uncontrolled escape of hazardous or flammable substances. The system operator must be trained to follow appropriate precautions and must inspect and maintain the system and its components including the product(s) and at regular intervals in accordance with timescales recommended by the supplier to prevent unacceptable wear or failure.



Milli-Mite® 1300 Series

Forged Metering Valves



Typical Applications

- Fine metering in medical and biochemical gas or vapor analysis
- Sampling and analyzing water and air pollution
- Chromatographs, mass spectrometers and other instruments where fine metering is required

Technical Data

BODY*	316 stainless steel, brass
MAXIMUM OPERATING PRESSURE @ 70° F (21° C)	Brass <ul style="list-style-type: none">• 3000 psig (207 bar) 316 stainless steel <ul style="list-style-type: none">• 5000 psig (345 bar)
OPERATING TEMPERATURE RANGE	Brass <ul style="list-style-type: none">-65 to 400° F (-54° to 204° C) 316 stainless steel <ul style="list-style-type: none">-65° to 450° F (-54° to 232° C)
ORIFICE	.047" (1.19 mm)
CV FACTOR	1° stem = .010 Cv 3° stem = .024 Cv

* Consult factory for other materials

Features & Benefits

- Metering accuracy - 18 turn displacement of stem provides unparalleled performance and repeatability
- 1° and 3° stems provide a wide flow range with ultra fine metering control
- Panel mounting is standard for all valves
- Precision orifice and close thread tolerances minimize hysteresis
- Micrometer vernier handle provides visual control and repeatable stem settings
- Dyna-Pak® wafer packing below the stem threads provides leak tight service
- Special High Tolerance NPT Thread

metering valves

Milli-Mite® 1300 Series

Materials of Construction

	DESCRIPTION	MATERIAL
1	Handle, black anodized	Aluminum Alloy
2	Set Screw	Alloy Steel
3	Graduated sleeve	302 SS
4	Metering Stem	316 stainless
5	Panel nut	Brass
6	Upper spacer	316 stainless
7	Dyna-Pak® wafer	PTFE
8	Lower spacer	316 stainless
9	Body	316 stainless or brass
10	Integrated seat & spacer	316 stainless
11	Orifice seal	PTFE

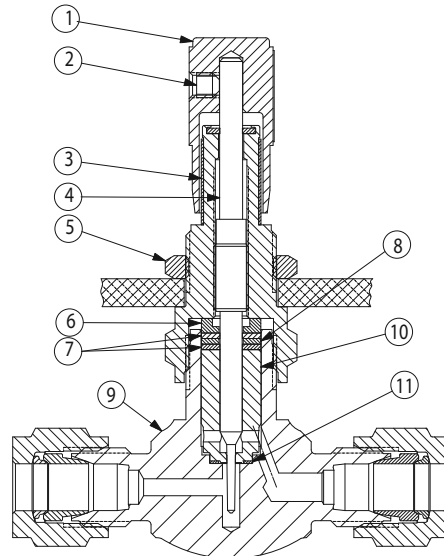

Dimensions

FLOW PATTERN	CONNECTIONS		DIMENSIONS		
	A INLET	B OUTLET	D	E	F
GLOBE	1/8" NPT Female	1/8" NPT Female	2.83"	1.75"	.50" 13mm
			72mm	44mm	
	1/8" NPT Male	1/8" NPT Male	3.25"	1.75"	
			83mm	44mm	
	1/8" NPT Male	1/8" GYROLOK®	3.25"	2.13"	
			83mm	54mm	
	1/4" NPT Male	1/4" NPT Male	3.25"	1.75"	
			83mm	44mm	
1/8" GYROLOK®	1/8" GYROLOK®	3.25"	2.38"		
		83mm	60mm		
1/4" GYROLOK®	1/4" GYROLOK®	3.25"	2.38"		
		83mm	60mm		
3mm GYROLOK®	3mm GYROLOK®	3.25"	2.38"		
		83mm	60mm		
6mm GYROLOK®	6mm GYROLOK®	3.25"	2.38"		
		83mm	60mm		
ANGLE	1/8" NPT Female	1/8" NPT Female	3.75"	1.28"	
			95mm	33mm	
	1/8" NPT Male	1/8" GYROLOK®	3.75"	1.28"	
			95mm	33mm	
	1/8" GYROLOK®	1/8" GYROLOK®	4.00"	1.63"	
			102mm	41mm	
	1/4" GYROLOK®	1/4" GYROLOK®	4.00"	1.63"	
			102mm	41mm	
3mm GYROLOK®	3mm GYROLOK®	3.25"	1.38"		
		83mm	41mm		
6mm GYROLOK®	6mm GYROLOK®	3.25"	1.38"		
		83mm	41mm		

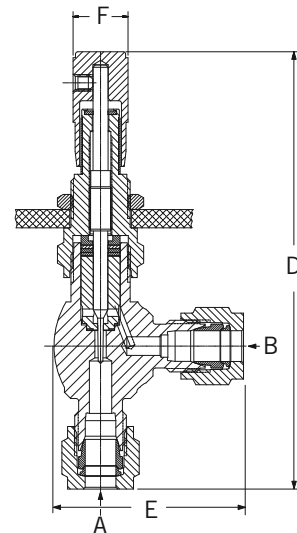
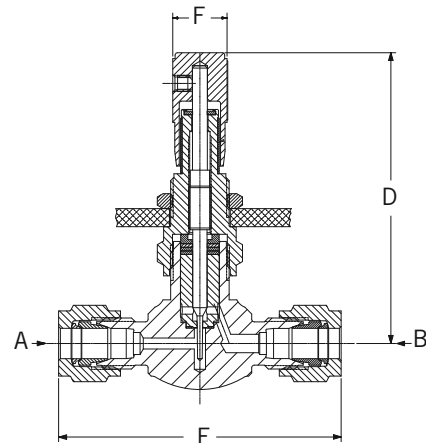

Dimensions for reference only, subject to change.

Panel mounting

Panel hole = .52" (13 mm) diameter

Panel thickness = .16" (4 mm) maximum

Milli-Mite® 1300 Series

Reference Flow Curves

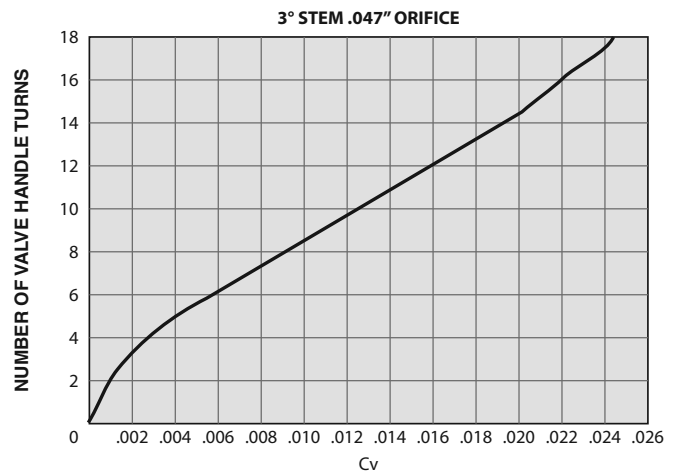
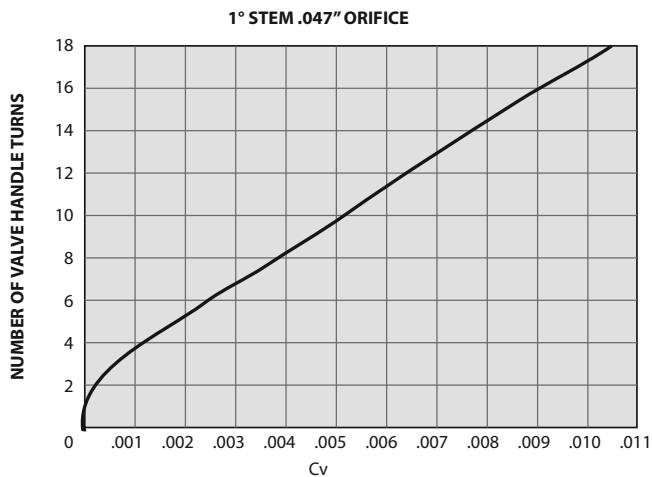

How to Order

FLOW PATTERN	CONNECTIONS		ORDER BY NUMBER			
	A INLET	B OUTLET	316SS VALVES		BRASS VALVES	
			1° STEM	3° STEM	1° STEM	3° STEM
			CV = 0.010	CV = 0.024	CV = 0.010	CV = 0.024
GLOBE	1/8" NPT Female	1/8" NPT Female	—	1315F2Y	—	—
	1/8" NPT Male	1/8" GYROLOK®	—	—	1335H2B	1315H2B
	1/8" NPT Male	1/8" NPT Male	—	—	1335M2B	1315M2B
	1/4" NPT Male	1/4" NPT Male	1335 M4Y	1315M4Y	1335M4B	1315M4B
	1/8" GYROLOK®	1/8" GYROLOK®	1335G2Y	1315G2Y	1335G2B	1315G2B
	1/4" GYROLOK®	1/4" GYROLOK®	1335G4Y	1315G4Y	1335G4B	1315G4B
	3mm GYROLOK®	3mm GYROLOK®	1335G3YMM	1315G3YMM	—	—
6mm GYROLOK®	6mm GYROLOK®	1335G6YMM	1315G6YMM	—	—	
ANGLE	1/8" NPT Female	1/8" NPT Female	—	—	1345F2B	1325F2B
	1/8" NPT Male	1/8" GYROLOK®	1345H2Y	1325H2Y	1345H2B	1325H2B
	1/8" GYROLOK®	1/8" GYROLOK®	1345G2Y	1325G2Y	1345G2B	1325G2B
	1/4" GYROLOK®	1/4" GYROLOK®	1345G4Y	1325G4Y	1345G4B	1325G4B
	3mm GYROLOK®	3mm GYROLOK®	1345G3YMM	1325G3YMM	—	—
	6mm GYROLOK®	6mm GYROLOK®	1345G6YMM	1325G6YMM	1345G6BMM	1325G6BMM
	1/8" NPT Female	1/8" NPT Female	—	—	1345F2B	—

Ordering Options

Spare Parts

Spare parts and repair kits are available for all needle valves. Please contact your distributor for specific information.

Cleaning and Testing

When ordering, please specify if oxygen cleaning or helium leak testing is required.

Additional Sizes

Additional sizes and options are available on special request. Please consult your local HOKE® distributor.



Micromite® 1600 Series

Forged Metering Valves



metering valves

Typical Applications

- Chromatography
- Mass Spectroscopy
- Sampling and fine metering
- Pollution analyzing instrumentation

Technical Data

BODY*	316 stainless steel, brass
MAXIMUM OPERATING PRESSURE @ 70° F (21° C)**	Brass <ul style="list-style-type: none">• 3500 psig (242 bar) 316 stainless steel <ul style="list-style-type: none">• 5000 psig (345 bar)
OPERATING TEMPERATURE RANGE	-20° to +250° F (-29° to +121° C)
ORIFICE	0.031" (0.79 mm)
CV FACTOR	0.0008

* Consult factory for other materials

** Valve is not designed for shut-off. Pressure ranges for metering only

Features & Benefits

- 18 turn non-rotating stem
- Low internal volume provides low flow control
- Non-rotating stem minimizes unwanted variability of flow rate
- Unique thread design allows tapered needle portion of the stem to be withdrawn into the outer stem
- O-ring seals below the stem threads provide smooth operation and eliminate backlash
- Panel mounting is standard for all models
- Dial indicator provides repeatable positioning of stem in full turns and tenths of a turn from closed to fully open.
 - Position by finger tip rotating the knurled aluminum dial.
 - A position lock prevents accidental movement of the handle and resulting errors in flow data.
 - The size and design of the handle assembly provide an attractive appearance for equipment panels.
- Special High Tolerance NPT Thread

Micromite® 1600 Series

Materials of Construction

	DESCRIPTION	MATERIAL
1	BODY	316 stainless or brass
2	O-RING	Fluorelastomer or Buna-N
3	O-RING	Fluorelastomer or Buna-N
4	PANEL NUT	Brass
5	WASHER	Fluorelastomer
6	WASHER	304 stainless
7	STEM AND PIN	316 stainless
8	SET SCREW	Alloy steel
9	HANDLE	Aluminum
10	SPINDLE	316 stainless
11	SCREW	316 stainless
12	FRICTION WASHER	Delrin® AF
13	FRICTION WASHER	Glass cloth
14	BONNET	316 stainless
15	RETAINER	PCTFE
16	GLAND	316 stainless
17	SEAT	316 stainless

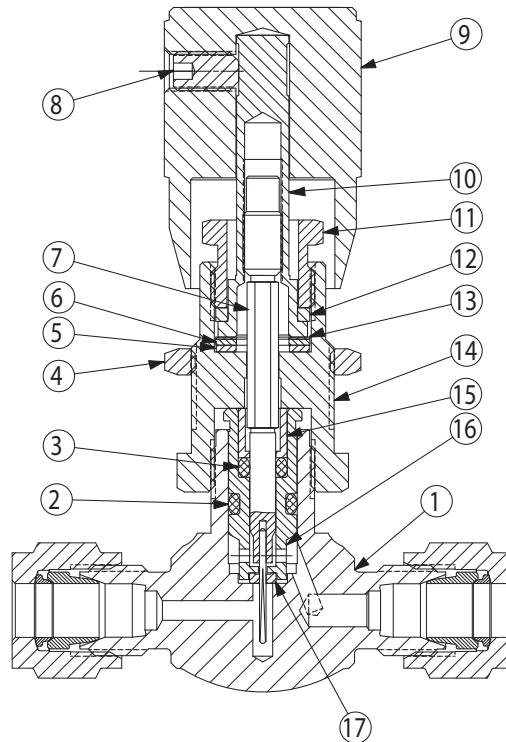

Micromite® 1600 Series

Dimensions

FLOW PATTERN	CONNECTIONS		PART NUMBER	BODY MATERIAL	O RING	DIMENSIONS			PANEL MOUNTING		
	A INLET	B OUTLET				D	E	F	MAXIMUM THICKNESS	HOLE SIZE	
GLOBE	1/8" FNPT	1/8" FNPT	1654F2BA	BRASS	Buna-N	mm	83	45	25	6	18
						inch	3 1/4	1 3/4	1	1/4	45/64
	1/8" MNPT	1/8" MNPT	1654M2BA	BRASS	Buna-N	mm	83	45	25	6	18
						inch	3 1/4	1 3/4	1	1/4	45/64
	1/4" MNPT	1/4" MNPT	1654M4BA	BRASS	Buna-N	mm	83	45	25	6	18
						inch	3 1/4	1 3/4	1	1/4	45/64
	1/16" GYROLOK®	1/16" GYROLOK®	1654G1BA	BRASS	Buna-N	mm	83	60	73	6	18
						inch	2 1/4	1 3/8	49	1/3	45/63
	1/8" GYROLOK®	1/8" GYROLOK®	1654G2BA	BRASS	Buna-N	mm	83	60	73	6	18
						inch	2 1/4	1 3/8	49	1/3	45/63
	1/4" GYROLOK®	1/4" GYROLOK®	1654G4BA	BRASS	Buna-N	mm	83	60	73	6	18
						inch	2 1/4	1 3/8	49	1/3	45/63
	1/8" FNPT	1/8" FNPT	1654F2YA	316 SS	Buna-N	mm	83	45	25	6	18
						inch	3 1/4	1 3/4	1	1/4	45/64
	1/8" MNPT	1/8" MNPT	1654M2YA	316 SS	Buna-N	mm	83	45	25	6	18
						inch	3 1/4	1 3/4	1	1/4	45/64
	1/4" MNPT	1/4" MNPT	1654M4YA	316 SS	Buna-N	mm	83	45	25	6	18
						inch	3 1/4	1 3/4	1	1/4	45/64
	1/16" GYROLOK®	1/16" GYROLOK®	1654G1YA	316 SS	Buna-N	mm	83	60	25	6	18
						inch	3 1/4	2 3/8	1	1/4	45/64
1/8" GYROLOK®	1/8" GYROLOK®	1654G2YA	316 SS	Buna-N	mm	83	60	25	6	18	
					inch	3 1/4	2 3/8	1	1/4	45/64	
1/4" GYROLOK®	1/4" GYROLOK®	1654G4YA	316 SS	Buna-N	mm	83	60	25	6	18	
					inch	3 1/4	2 3/8	1	1/4	45/64	
1/16" GYROLOK®	1/16" GYROLOK®	1656G1YA	316 SS	Fluorelastomer	mm	83	60	25	6	18	
					inch	3 1/4	2 3/8	1	1/4	45/64	
1/8" GYROLOK®	1/8" GYROLOK®	1656G2YA	316 SS	Fluorelastomer	mm	83	60	25	6	18	
					inch	3 1/4	2 3/8	1	1/4	45/64	
1/4" GYROLOK®	1/4" GYROLOK®	1656G4YA	316 SS	Fluorelastomer	mm	83	60	25	6	18	
					inch	3 1/4	2 3/8	1	1/4	45/64	
1/16" GYROLOK®	1/16" GYROLOK®	1666G1YA	316 SS	Fluorelastomer	mm	83	60	25	6	18	
					inch	3 1/4	2 3/8	1	1/4	45/64	
1/8" GYROLOK®	1/8" GYROLOK®	1666G2YA	316 SS	Fluorelastomer	mm	102	41	25	6	18	
					inch	4	1 5/8	1	1/4	45/64	
1/4" GYROLOK®	1/4" GYROLOK®	1666G4YA	316 SS	Fluorelastomer	mm	102	41	25	6	18	
					inch	4	1 5/8	1	1/4	45/64	

Dimensions for reference only, subject to change.

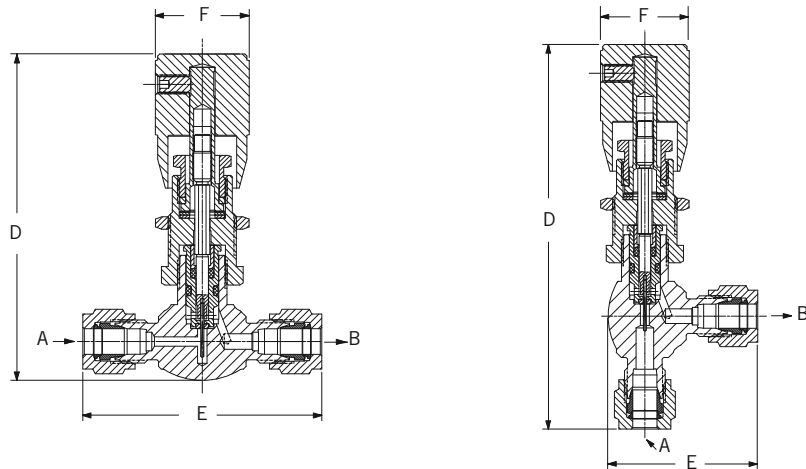

Micromite® 1600 Series

Reference Flow Curve

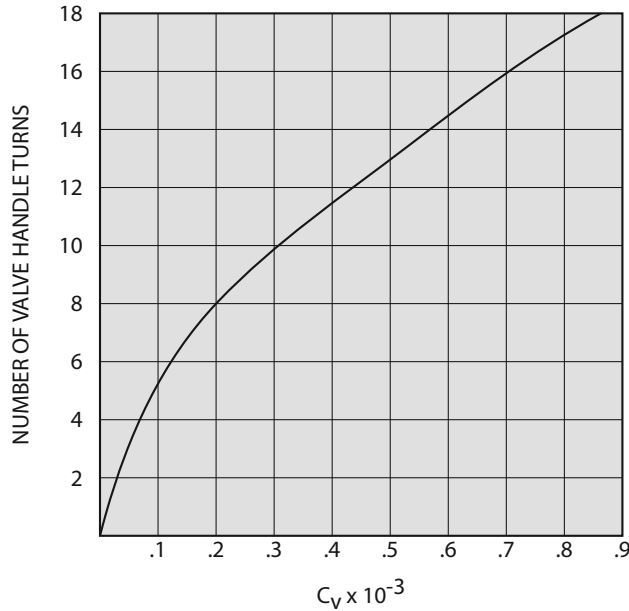

Metering range is approximately 18 handle turns. Opening the valve beyond the metering range will increase the flow to full C_v .

How to Order

FLOW PATTERN	CONNECTIONS		BRASS WITH BUNA-N	316 STAINLESS STEEL WITH BUNA-N	316 STAINLESS WITH FLUORELASTOMER
	A Inlet	B Outlet			
GLOBE	1/8" FNPT	1/8" FNPT	1654F2BA	1654F2YA	—
	1/8" MNPT	1/8" MNPT	1654M2BA	1654M2YA	—
	1/4" MNPT	1/4" MNPT	—	1654M4YA	—
	1/16" GYROLOK®	1/16" GYROLOK®	1654G1BA	1654G1YA	1656G1YA
	1/8" GYROLOK®	1/8" GYROLOK®	1654G2BA	1654G2YA	1656G2YA
	1/4" GYROLOK®	1/4" GYROLOK®	1654G4BA	1654G4YA	1656G4YA
ANGLE	1/16" GYROLOK®	1/16" GYROLOK®	—	—	1666G1YA
	1/8" GYROLOK®	1/8" GYROLOK®	—	—	1666G2YA
	1/4" GYROLOK®	1/4" GYROLOK®	—	—	1666G4YA

To Order the Dial Indicator, order Kit **1600K4**. If valve and kit are to be factory assembled, please note "Factory Assembled" on order

Ordering Options

Spare Parts

Spare parts and repair kits are available for all needle valves. Please contact your distributor for specific information.

Cleaning and Testing

When ordering, please specify if oxygen cleaning or helium leak testing is required.

Additional Sizes

Additional sizes and options are available on special request. Please consult your local HOKE® distributor.



2300 Series

Bar Stock Metering Valves



metering valves

Typical Applications

- Metering liquids and gases on analytical equipment
- Laboratory sampling
- Gas chromatography, analyzers
- Flow meters and gauges

Technical Data

BODY*	316 stainless steel, brass
MAXIMUM OPERATING PRESSURE	<i>Brass</i> <ul style="list-style-type: none"> • 3000 psig up to 200° F (207 bar @ 93° C) <i>316 stainless steel</i> <ul style="list-style-type: none"> • 3000 psig 100° F (207 bar @ 38° C) • 1000 psig 250° F (68.9 bar @ 121° C)
OPERATING TEMPERATURE RANGE	<i>Buna N O-ring Packing</i> <ul style="list-style-type: none"> • -40° to 200° F (-40° to 93° C) <i>PTFE Packing</i> <ul style="list-style-type: none"> • -60° to 250° F (-51° to 121° C)
ORIFICE	.062", .125" (1.59 mm, 3.17 mm)
CV FACTOR**	1° stem, 0.062" orifice: 0.012 8° stem, 0.062" orifice: 0.086 8° stem, 0.125" orifice: 0.30

* Consult factory for other materials

** Cv factors shown are based on flow through entire metering range, approximately 20 handle turns

Features & Benefits

- Micrometer vernier handle provides visual control and precise establishment of flow settings. To order, specify **2300K1** following the valve number.
- 20 turn stem displacement for fine metering
- 2 orifice sizes 0.062" (1.59mm) and 0.125" (3.17mm) are available with standard 8° stem
- Spring loaded stem in all 316 stainless steel valves prevents galling and enlargement of the orifice.
- For ultra fine metering, a 1° spring loaded stem design is available for all valves with 0.062" (1.59mm) orifice. See flow curves for details.
- Panel mounting is standard on all valves
- Bonnet lock prevents accidental disengagement of bonnet.
- Special High Tolerance NPT Thread

2300 Series

Materials of Construction

316 Stainless Steel Valves (PTFE Packing)

	DESCRIPTION	MATERIAL
1	CAP NUT (10-24)	Zinc Alloy
2	HAND WHEEL*	Nylon
3	WASHER	PTFE
4	PACKING	PTFE
5	PACKING NUT	316 stainless
6	MOUNTING NUT	316 stainless
7	HOUSING	316 stainless
8	BODY	316 stainless
9	SPINDLE POINT	316 stainless
10	SEAT	PCTFE
11	SEAT HOLDER	316 stainless
12	BALL	316 stainless
13	COMPRESSION SPRING	316 stainless
14	STEM	316 stainless

* Optional micrometer handle - Aluminum

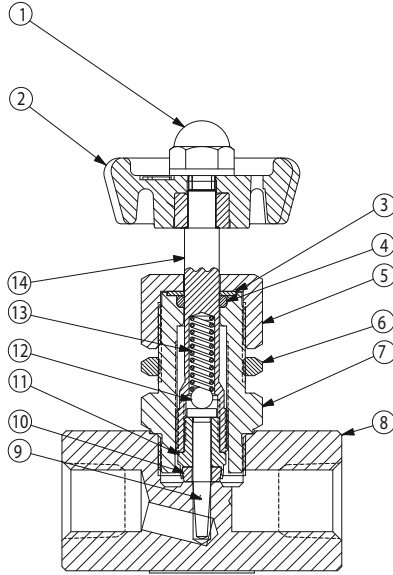

2335F[JY / 2315F[JY
stainless steel

Brass Valves (Buna-N Packing)

	DESCRIPTION	MATERIAL
1	CAP NUT (10-24)	Zinc Alloy
2	HAND WHEEL*	Nylon
3	STEM	316 stainless
4	WASHER	Nylon
5	O-RING	Buna-N
6	PACKING NUT	Brass
7	MOUNTING NUT	FCB
8	HOUSING	Brass
9	BODY	Brass

* Optional micrometer handle - Aluminum

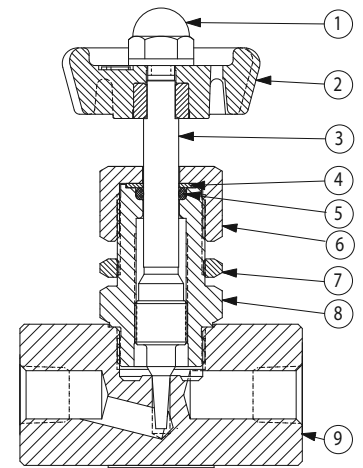

2331F[JB
Brass

Dimensions

FLOW PATTERN	A & B CONNECTIONS	PANEL MOUNTING DIMENSIONS									
			D	D'	E	F	F'	H	H'	PANEL THICKNESS	HOLE SIZE
GLOBE	¼" NPT FEMALE	inch	3.59	3.88	2	1.41	1	0.5	0.75	0.13	0.64
		mm	91	98	51	36	25	12.7	19	3	16
	½" NPT FEMALE	inch	3.59	3.88	2	1.41	1	0.5	0.75	0.13	0.64
		mm	91	98	51	36	25	12.7	19	3	16
	¼" GYROLOK®	inch	3.59	3.88	2.63	1.41	1	0.5	0.75	0.13	0.64
		mm	91	98	67	36	25	12.7	19	3	16
ANGLE	¼" NPT FEMALE	inch	3.75	4.06	1.44	1.41	1	0.56	0.81	0.13	0.64
		mm	95	103	37	36	25	14	21	3	16
	½" NPT FEMALE	inch	3.75	4.06	1.44	1.41	1	0.56	0.81	0.13	0.64
		mm	95	103	37	36	25	14	21	3	16

Dimensions for reference only, subject to change.

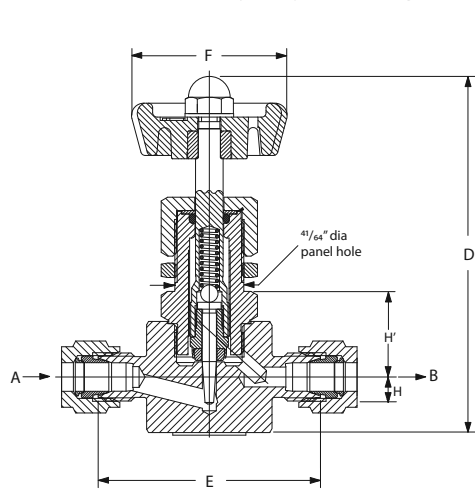

2335G[JY / 2315G[JY
316 stainless steel

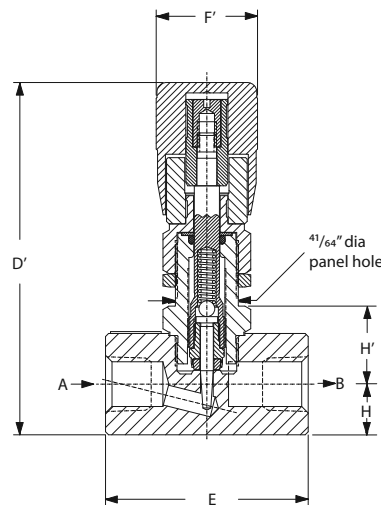

2335F4Y / 2315F4Y
316 stainless steel
(with optional micrometer handle)

2300 Series

Curves

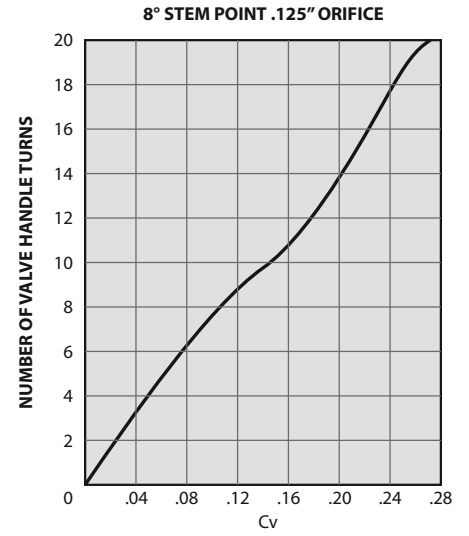
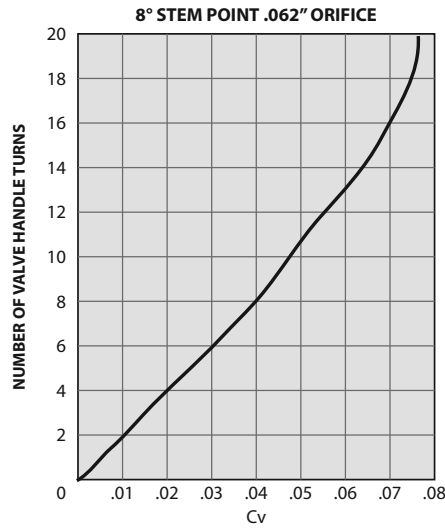
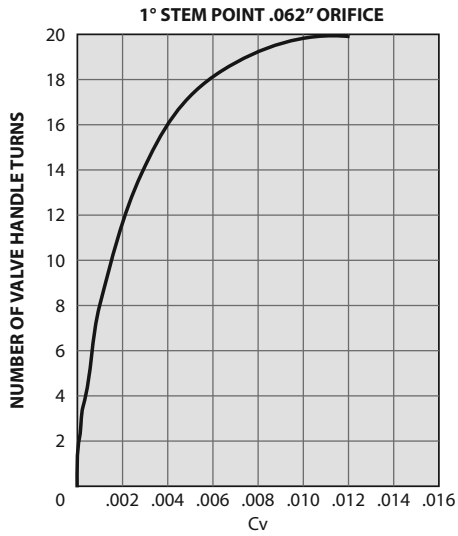

How to Order

FLOW PATTERN	CONNECTIONS	316 STAINLESS STEEL VALVES			BRASS VALVES	
		PTFE PACKING			BUNA-N O-RING PACKING	
		1° STEM SPRING LOADED	8° STEM SPRING LOADED	8° STEM SPRING LOADED	SOLID 8° STEM	SOLID 8° STEM
		.062" ORIFICE	.062" ORIFICE	.125" ORIFICE	.062" ORIFICE	.125" ORIFICE
GLOBE	1/8" NPT FEMALE	2355F2Y	2315F2Y	2335F2Y	2311F2B	2331F2B
	1/4" NPT FEMALE	2355F4Y	2315F4Y	2335F4Y	2311F4B	2331F4B
	1/4" GYROLOK®	2355G4Y	2315G4Y	2335G4Y	—	2331G4B
ANGLE	1/8" NPT FEMALE	—	—	—	2321F2B	2341F2B
	1/4" NPT FEMALE	—	—	—	2321F4B	2341F4B

Ordering Options

Spare Parts

Spare parts and repair kits are available for all needle valves. Please contact your distributor for specific information.

Cleaning and Testing

When ordering, please specify if oxygen cleaning or helium leak testing is required.

Additional Sizes

Additional sizes and options are available on special request. Please consult your local HOKE® distributor.

2300 Series

Liquid Flow capacity of HOKE Metering Valves

To determine the Cv or flow of a **liquid** @ 60° F (16° C):

$$Cv = \frac{GPM}{\sqrt{\frac{\Delta p}{S.G.}}} \quad \text{or} \quad GPM = Cv \sqrt{\frac{\Delta p}{S.G.}}$$

where: $\Delta p = p_1 - p_2$
 p_1 = inlet pressure in psia
 p_2 = outlet pressure in psia
 GPM = flow in gallons per minute
 S.G. = specific gravity of liquid where water = 1.0 @ 60° F (16° C)

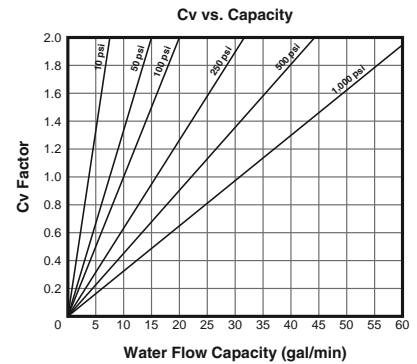

Gas Flow capacity of HOKE® Metering Valves

To determine the Cv or flow of a **gas** @ 70° F (21° C):

$$Cv = \frac{SCFH}{1360 \sqrt{\frac{(\Delta p)(p_1)}{(460 + T)(S.G.)}}} \quad \text{or} \quad SCFH = 1360 Cv \sqrt{\frac{(\Delta p)(p_1)}{(460 + T)(S.G.)}}$$

where: $\Delta p = p_1 - p_2$
 p_1 = inlet pressure in psia
 p_2 = outlet pressure in psia
 SCFH = flow in standard cubic feet per hour
 S.G. = specific gravity of gas where air = 1.0 @ 70° F (21° C) and 14.7 psia
 T = temperature in ° F

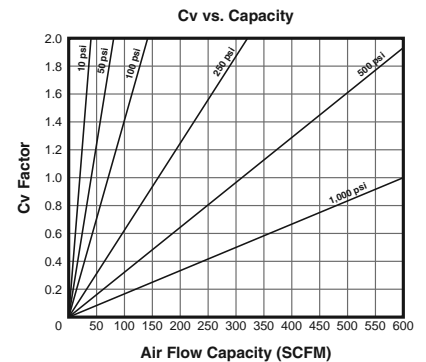

Specifying metering valves for critical analytical instrumentation and applications which demand precise stem positioning requires a complete knowledge of your process conditions.

Before you start, it is important that your flow requirements be defined in terms of Cv or flow coefficient.

Cv is the valve flow coefficient expressing the rate of flow in gallons per minute of 60° F water with a pressure drop of 1 PSI across the valve. By correctly using the formula for liquids or gases, you will obtain an accurate Cv, necessary for your valve selection.

Cv should be calculated for expected variations in pressure and required flow range. The Cv range for HOKE® metering valves is approximately 10 to 1. This is illustrated in the Cv vs handle turns flow curves shown with each valve series. Note that the more handle turns required to achieve a specified change in flow, the greater the valve's accuracy.

The Cv range providing best control should fall within the straight portion of the curve with the nominal value centered. Using the straight portion of the curve gives approximately the same incremental flow for each turn of the valve handle.

Once Cv requirements are determined, the following steps must be evaluated before making your final valve selection.

1. Define Pressure/Temperature Requirements

HOKE® metering valves are available from moderate vacuum to 5000 psig. Operating temperatures range from -65° to 450° F. There are no restrictions on pressure drop or downstream pressure for HOKE® valves, however, best performance will be obtained if the downstream pressure is more than 50% of the inlet pressure.

2. Know Your Material Requirements

Corrosion resistance should be your prime consideration when selecting materials, particularly the wetted or pressure boundary parts. There are times when the environment must also be considered in addition to the fluid media.

The pressure/temperature demands of materials are normally covered by the material manufacturer's product specifications.

HOKE® products are designed using materials of similar corrosion properties whenever possible. If material selection is critical, please contact your nearby HOKE® distributor. He can recommend options to help solve your problem.

3. Options

Dial Indicator and micrometer handles are available for reproducing stem positioning. The HOKE® Milli-Mite 1300 series is provided with a micrometer handle as standard equipment. Other handle options are available or can be made to order.

4. Final Performance

Engineering design and manufacturing standards are critical elements of the metering valve you select and will affect its actual performance.

Total control of these quality elements at HOKE® assures you of valves with excellent stem positioning repeatability, low hysteresis, and extended metering range.

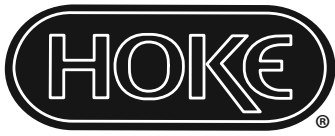

The Small Bore Instrumentation Specialists



We specialize in small bore instrumentation products up to 2" that deliver benchmark performance quality & safety; provide the broadest array of superior alloy offerings in the market; decades of proven success in a wide range of industries; a roster of "who's who" customers & projects globally; original "Best Solution" engineering & designs; and are focused on continuous improvement in all aspects of our business.

Proudly Distributed By:



CRANE INSTRUMENTATION &
SAMPLING Inc.
405 Centura Ct.
Spartanburg, SC 29305, USA
Tel: 1-864-574-7966
PO Box 4866, Spartanburg, SC
29305-4866 USA

Crane Co., and its subsidiaries cannot accept responsibility for possible errors in catalogues, brochures, other printed materials, and website information. Crane Co. reserves the right to alter its products without notice, including products already on order provided that such alteration can be made without changes being necessary in specifications already agreed. All trademarks in this material are the property of the Crane Co. or its subsidiaries. The Crane and Crane brands logotype (CENTER LINE®, COMPAC-NOZ®, CRANE®, DEPA® & ELRO®, DOPAK®, DUO-CHEK®, FLOWSEAL®, GYROLOK®, GO REGULATOR®, HOKE®, JENKINS®, KROMBACH®, NOZ-CHEK®, PACIFIC VALVES®, RESISTOFLEX®, REVO®, SAUNDERS®, STOCKHAM®, TEXAS SAMPLING®, TRIANGLE®, UNI-CHEK®, VALVES®, WTA®, and XOMOX®) are registered trademarks of Crane Co. All rights reserved.