



Engineering For The Future

progressive
passionate
Innovative
technology
customer centric



FLUID CONTROLS



Engineering For The Future

Philosophy of Design

- Reliable performance
- Adhere to high demand application
- Product life cycle management
- Minimal "Total Cost of Ownership"

Research and Development

- Culture of constant innovation
- Adherence to International Design Standards
- Innovative designs to meet customers' demands
- In-house Validation Labs
- Patents and IP Rights Management

Skilled Manpower

- Highly skilled, engaged and connected team
- Focussed "Learning and Development" approach
- Virtual cross functional team

Trust

- Large base of 6500 satisfied customers
- Earned reputation of being "Right First Time" with consistent high quality
- ROTEX products are trusted for critical applications by customers

New Product Development

- Innovative new product lines introduced by responding to the voice of the customer
- > 15 % of CAGR is achieved through new products
- Patents to help customers gain maximum benefits
- Extensive product testing prior to launch

Manufacturing

- State-of-the-art manufacturing plants
- Hi-tech automation using Robots, Process digitisation, Poka Yoke, Vision Cameras, etc.
- ISO 9001, ISO 14001 and OHSAS 18001 for all manufacturing plants
- IATF 16949 and AS 9100D for Vadodara unit
- Automated testing facilities

Customised Solutions

- Product introduction through gradual horizontal integration
- End to end solutions
- Quick solution for customised application

Quality

- Quality is at the heart of our complete value chain
- Effective quality management systems
- Partnership with high quality suppliers
- Strong quality improvement cycle

Marketing and Service

- Highly specialised Product Management team
- Expertise in providing bespoke solutions
- Customer centric approach

Certification

- Global Product Certifications
- ATEX, CuTR, DGMS, IECEX, KOSHA, PED, PESO, SIL 3, UL etc.
- Dedicated design, and validation team

Building Blocks of
ROTEX

Quality minus excuses



Product Certification



System Certification



Design Standard and Accreditation

ROTEX products pass through a strict regimen of quality and performance tests.

ROTEX has an extensive and highly advanced in-house Type Testing facilities like High Pressure Test (up to 700 bar), Mass Spectro-Helium Leak Detection Test (up to 1×10^{-12} scc/sec), CV Measurement, Response Time, Life Cycle Monitoring, Environment, Thermal Shock Test, and more.

Specialised Simulation Software are used for Design integrity check, Mold Flow, Electromagnetic Force etc. to ensure proper functioning of the products.

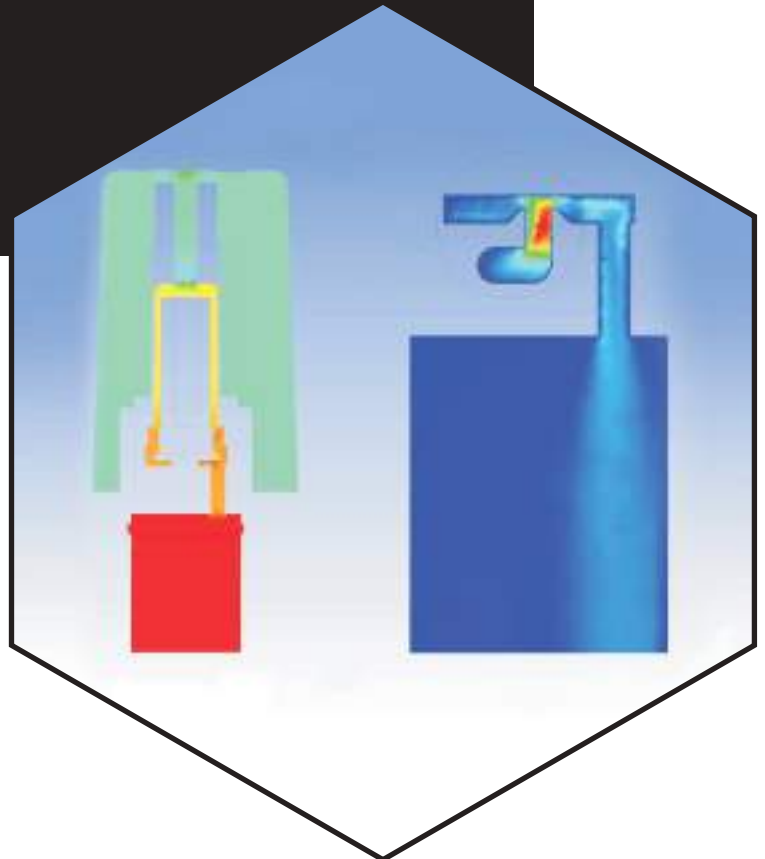
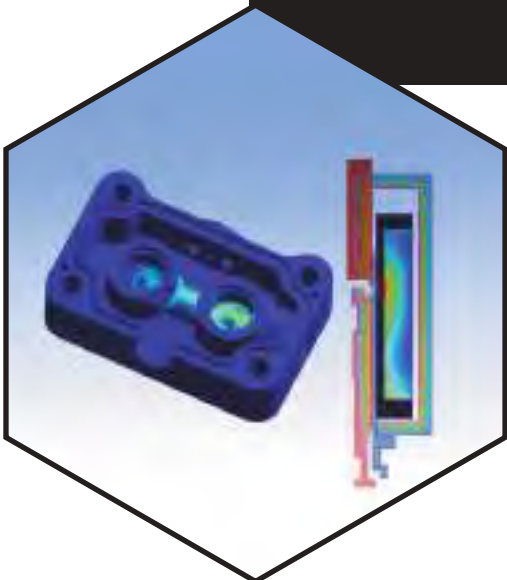

State-of-the-art Infrastructure

ROTEX rolls out its vast range of productions from two world class manufacturing facilities located in India. All plants have the latest and the most advanced manufacturing and testing facilities. These facilities have the latest generation CNC, SPM and GPM machines to manufacture quality components.

ROTEX has developed a strong base of vendors and suppliers for outsourcing of components. Strict inspection and testing procedures ensure that outsourced material meets all the ROTEX quality requirements. Periodic expansion of the manufacturing facilities and infrastructure in response to the market demand and technology innovations, is an ongoing process at ROTEX.

All the important manufacturing processes are executed In-house conforming to International Standards.





State-of-the-art **Solenoid**



State-of-the-art Infrastructure for Solenoid

ROTEX manufactures 100% of its Solenoid requirements In-house. The manufacturing begins with unmanned winding of wire on the bobbin till vacuum epoxy potting.

ROTEX has nearly five decades of experience in design and manufacturing of Solenoids for varied applications.

Over the period, ROTEX has invested in modern Infrastructure to move from manual to highly automated Solenoid manufacturing. ROTEX ensures implementation of latest Design and testing standards in its operation.

ROTEX Solenoids goes through 29 rigorous inspection processes before being shipped out to the customer. ROTEX designs are suitable for the vast range of applications:

- High speed to continuous energisation
- Low temperature -60°C
- High temperature 270°C above ambient

ROTEX offers Solenoid valves with power ranging from 0.4 Watt to 140 Watt to meet most of the industry demand.



Sales Network Implementing a Think Global, Act Local Approach!!!

It is the philosophy of ROTEX to build long-term relationships with its Agents, Channel partners, and Distributors by integrating a transparent and honest policy. Most of the Agents, Channel partners, and Distributors have been associated with ROTEX for decades and some of them for more than a Quarter century.

ROTEX has a far-reaching network of over 20 offices in Asia, and Europe, along with more than 130 Channel partners and Distributors across the Globe. ROTEX has wide network of sales and service associates, to provide quick and efficient support wherever and whenever needed.

In order to maintain consistency in quality and service, ROTEX undertakes regular training for all its Partners.

After Sales Support

Standardised processes, learning and improvement are incorporated in the sales support processes. These are indispensable and ROTEX has imbibed them in its after sales strategy since its inception to foster sustainability.





Manufacturing Unit



Rotex Office



Sales & Service Associate



Sales
and
Service
Network

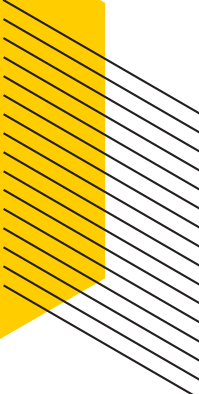

Features

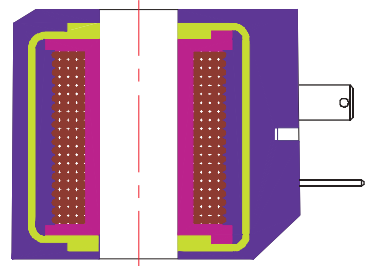
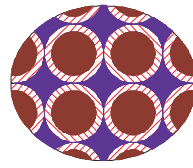

Design Features of ROTEX Solenoid

Efficient Magnetic Linkage

- Higher Pulling Force

More winding & Void space between winding, filled with Epoxy

- Lower Temperature Rise & better Insulation

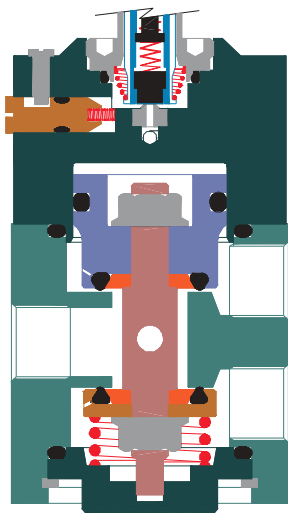

Design Features of ROTEX Plunger

Lower Stroke

- Faster Operations and Large Flow

Positive Sealing

- Longer Life

No Stress on Seat Seal while seating

Interchangeability of Rotex Solenoid

- Wider Voltage Variation - -30% to +20%
- Lower Inrush current for all AC Solenoids
- Epoxy coated Metallic Enclosure
- Ingress Protection upto IP 68
- Surge Suppressor in all Ex d, Ex ia, Ex e mb Solenoid

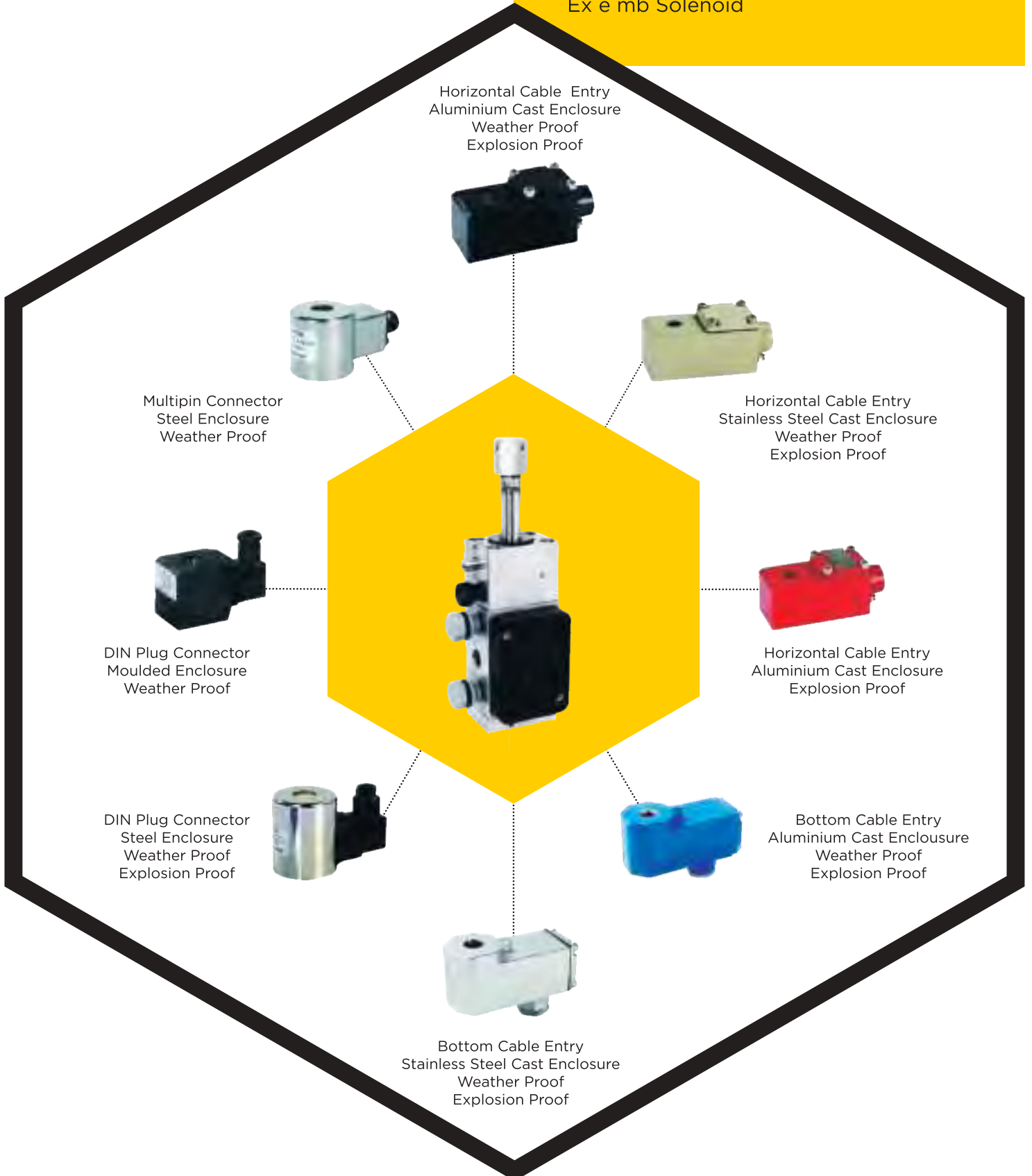

Fluid Controls

2 Port Solenoid Valve

- Direct Acting - NC / NO / Bi - Directional
- Diaphragm Operated - NC / NO
- Isolated Piston - NC / NO / Bi Directional
- High Pressure - upto 400 bar & 100 mm orifice
- Air Operated Valve

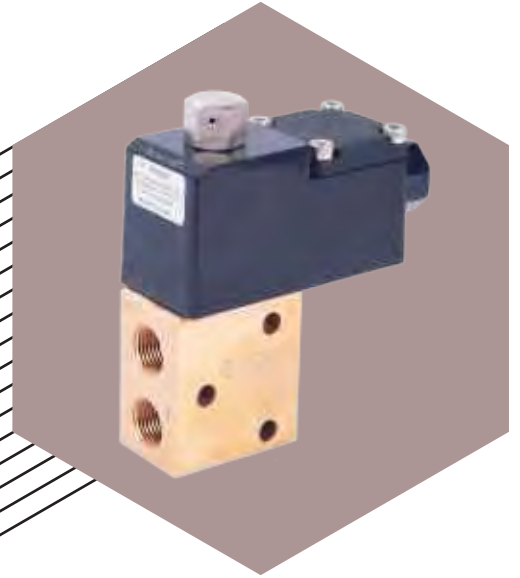

3 Port Solenoid Valve

- Direct Acting - NC / NO / Universal
- Internal / External Pilot Operated - NC / NO / Universal Valve
- High Pressure / High Orifice Valve
- Air Operated Valve

5 Port Solenoid Valve

- Single / Double Solenoid Valve
- High Pressure Valve
- Centre Off / Pressurized / Exhaust Solenoid Valve
- Air Operated / Air Return Valve

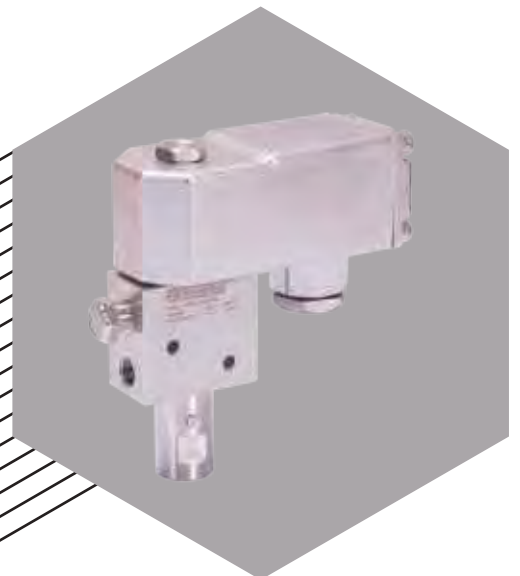

Engineered Valve

- Redundant Valve - 1oo2, 2oo2, & 2oo3
 - Manual Reset
- Tamper Proof Manual Reset Valve
 - Valve with Latch Solenoid
- Valve with Ultra Low Power (0.4 W) Solenoid

Fluid Controls

Angle Seated Valve

- Orifice up to 80 mm
- End Connection
 - Threaded
 - Flanged
 - Weld Neck
 - Tri clamp type
- ON/OFF or Proportionate Application



Pulse Jet Valve

- Orifice upto 80 mm
- High pressure upto 16 bar and 200 Deg C Temp
 - End connections
 - Threaded
 - Tank Mounted
 - Dresser Coupling

Electro Hydraulic Actuator

- On Off
- Modulating
- Communication Protocol - Modbus / Profibus / HART / FF

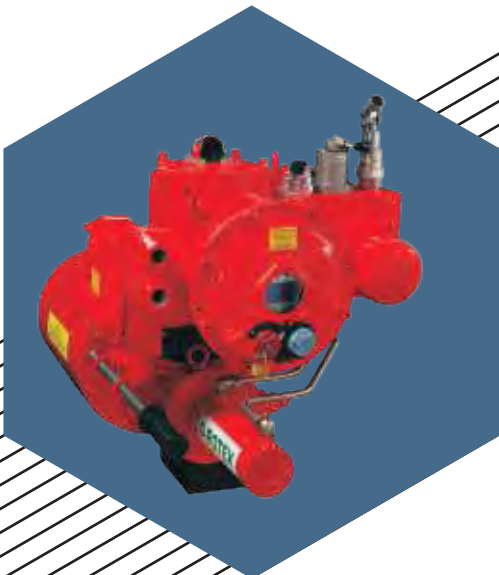

Positioners

- P / P Positioner
- E / P Positioner
- SMART Positioner



Chemical & Pharma

HIGH RELIABILITY PRODUCT FOR CLEAN ROOM ENVIRONMENT

Chemical plants have corrosive and aggressive environments. Such plants need products that are not only reliable but also capable to withstand such abuse. ROTEX manufactured valves are specially designed to function smoothly in such an environment and withstand the effects of highly corrosive Chemicals.

Challenges met by ROTEX

- SIL 3 certified product for reliable functionality
- Solenoid valves to work under sticky environmental Conditions
- Corrosive atmosphere Solution with Stainless Steel material of construction.
- Low power (0.4 W, Ex ia) solution to meet Industries Demand.



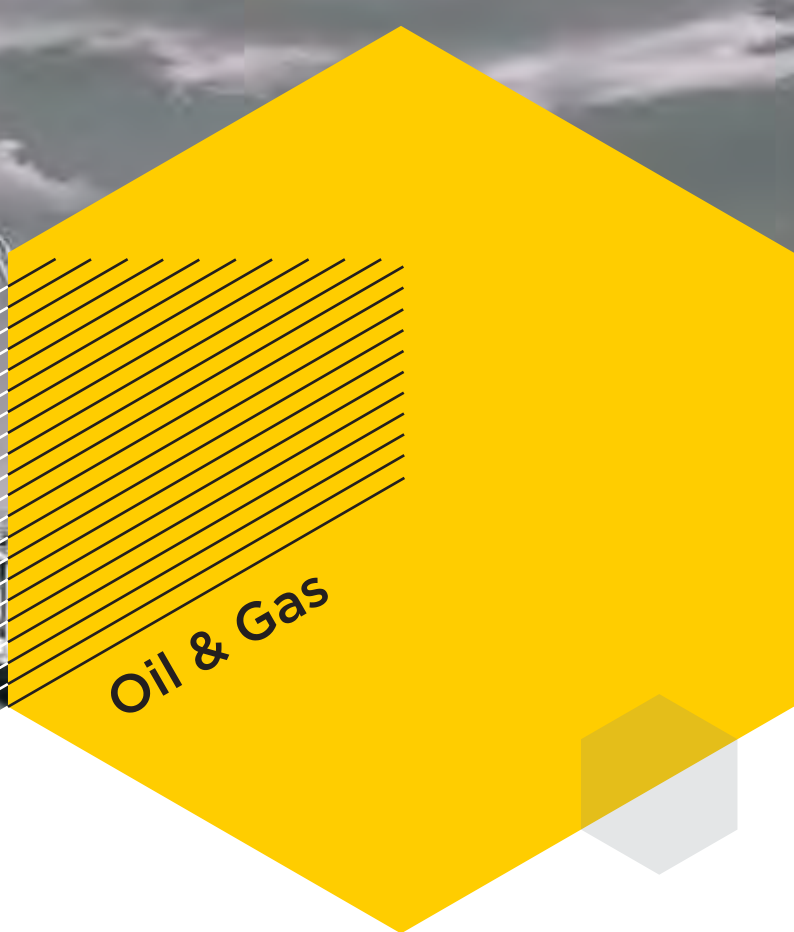

Oil & Gas

LOW POWER SOLUTION FOR CRITICAL OPERATION

Valves used in oil refineries, petrochemical plants and natural gas distribution companies are critical and hence there can be no compromise in their operation. ROTEX offers reliable valves that prevent hazards.

Challenges met by ROTEX

- Redundant SIL 3 Certified Solenoid Valve block for critical application
- Solenoid valves for 200 bar
- Redundant Control System for Emergency Shut Down Valve
- Valve for Fire Protection, Rim Seal Protection application

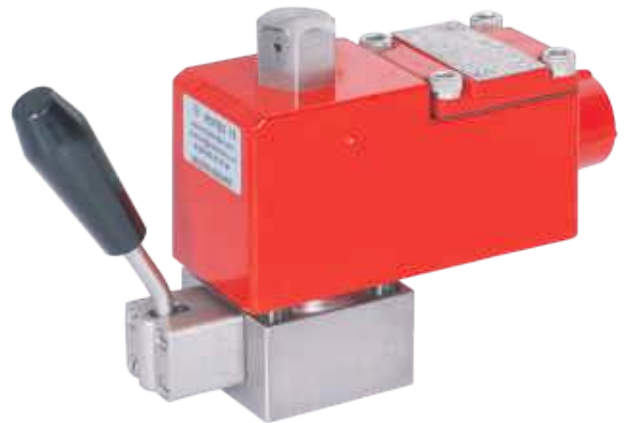



Cement

CONSISTENT PERFORMANCE IN DUSTY ENVIRONMENT

Consistent performance and efficient operations are vital for Cement plants. ROTEX offers specially designed basket of Pneumatic and Solenoid Valves. ROTEX meets the requirement of long life and consistent performance for cement industry.

Challenges met by ROTEX

- Pulse valve with Hytrel Diaphragm for high cyclic Demand
- Quick Opening and Closing, using optimal Air and Power / Pulse for effective Bag filter cleaning
- Three, & Five Port Valve suitable for dusty environment.





Automotive

HIGH PERFORMANCE AUTOMOTIVE VALVES FOR OFF ROAD & ON ROAD VEHICLES

ROTEX has successfully designed and manufactured many solutions for the Automotive segment for various applications like DPF regeneration systems, Exhaust brakes, Fuel shut off, Transmission system, Tipping applications, HVAC, Differential locking and many more. ROTEX manufacturing plants are ISO 9001, ISO 14001, OHSAS 18001, IATF 16949 certified, and qualified for VDA 6.3 QMS.

Challenges met by ROTEX

- IP6K9K solenoid to withstand 100 bar water pressure jet and high velocity sand abrasion
- Component designed to withstand extreme vibrations up to 56g
- Leak rates as low as 1 mm³/sec of H₂ at 10 bar for mass production run
- Less than 50 PPM quality performance





CORROSION RESISTANT SOLENOID VALVES

Fertilizer industry requires the toughest and the most technologically advanced products as wear and corrosion is very high. ROTEX manufactures products using a combination of alloys and elastomers that can handle severe wear and corrosion.

Challenges met by ROTEX

- Wear resistant solenoids valves for severe application
- Redundant Control System with 1oo2, 2oo2, 2oo3
- SIL 3 certified product for critical application
- Solenoid valves for Ammonia Environment





Power-Thermal

VALVES FOR DUSTY AND HIGH TEMPERATURE ENVIRONMENT

Thermal Power plants require valves that can sustain high levels of extreme Temperature and Pressures. At ROTEX, valves are designed and engineered with the objective of sustaining the most adverse conditions.

Challenges met by ROTEX

- Rugged Poppet Solenoid Valve
- Solenoid isolated for Voltage and Thermal shocks
- Solenoid Valves for Boiler Applications.
- Solenoid Valves for Turbine Trip Application
- Valves for Ash and Coal Handling, Dust Suppression, and Water Treatment





Mines & Metal

SOLENOID VALVES FOR HIGH TEMPERATURE APPLICATION

In Mines & Metal industry maximum system availability & safety is of utmost importance. ROTEX valves are manufactured from high quality materials, which have been tried and tested to withstand the extreme environmental challenges posed by Mines & Metal Industry.

Challenges met by ROTEX

- Special Valve Block for Operating Cylinder - Crest Cracking of Molten Aluminum
- High Orifice valve for Operating Air Motor of Copper Smelter
- Valves for Blast Furnace
- Pulse Jet Valves for Steel Plants





Power Nuclear

NEXT GEN VALVE FOR ULTRA CRITICAL AND MISSION SAFE APPLICATION

The biggest apprehension for any Nuclear Power Industry is safety. At ROTEX, we understand the criticality and manufacture high quality and reliable safety solenoid valves. Our products are designed to work even under extraordinary conditions, high temperatures and radiation protected environment.

Challenges met by ROTEX

- Direct acting solenoid valve 80 NB, for Helium at 0-120 bar, response OFF < 100 mS
- 4/2 solenoid valve for water at 100 bar
- Solenoid with special epoxy potting for withstanding GAMMA radiation
- Specially designed products to meet Seismic qualification & service of life of 30 years





Medical

HIGH RESPONSIVE VALVES WITH HIGH RELIABILITY

Medical industry requires reliable and highly responsive Pneumatic components, with extremely low leak rate meeting statutory requirement of USFDA, and other Governing bodies. ROTEX offer solenoid valves which can be used to control the flow, direction, and pressure of gases or fluid in a medical devices.

Challenges met by ROTEX

Valves for

- Portable gas delivery system
- Dialysis Machine
- Dental Chairs





Railways

VALVES DESIGNED TO WITHSTAND HIGH VIBRATION AND VOLTAGE VARIATION

Rail transport industry calls for product which are extremely reliable, even under the most demanding environmental conditions. Extreme weather phenomena, high level of vibration, the presence of dust and aggressive contamination, and huge voltage variation are common factors under which product needs to perform.

Challenges met by ROTEX

- Valves for Braking application
- Pneumatic Wiper Motor assembly
- Valves for Warning Horn.
- Fire Fighting Valves for Rolling Stock.

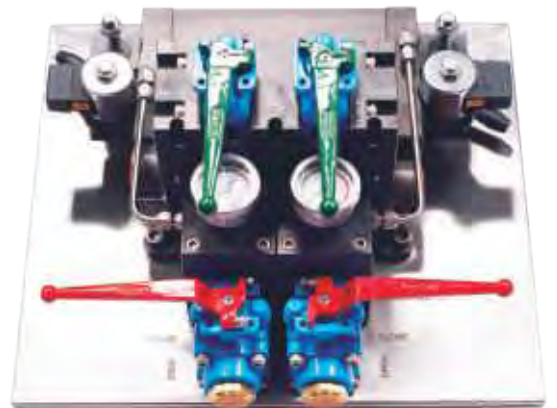



SALES HO

ROTEX AUTOMATION LIMITED
B/703/704, Western Edge-II,
Off Western Express Highway,
Borivali (East), Mumbai-400066
Ph: +91 22 4211 1444

WORKS

ROTEX AUTOMATION LIMITED
987/11, GIDC Makarpura,
Vadodara-390010,
Gujarat, India.
Ph. : +91 265 6174100

ROTEX AUTOMATION LIMITED
C - 1 B/ 1501, 4 & 5, GIDC
Vithal Udyognagar-388121,
Gujarat, India.
Ph. : +91 2692 236224



@rotexautomation



www.rotexautomation.com



info@rotexautomation.com